

Around Tokuyama's Formula

Santi Aranguri, Logan Bell, Chavdar Lalov, and Robin Truax

June 2021

Abstract

Tokuyama's formula offers a link between combinatorics and representation theory. Namely, it interprets an expression involving the characters of general linear groups as being a sum over one of three combinatorial objects: Gelfand-Tsetlin patterns, shifted tableaux, or gamma ice models. We first review existing literature concerning Tokuyama's formula and then present two novel proofs which avoid complicated machinery required by previous proofs. We have describe progress in extending our results toward an analogous combinatorial identity for the characters of symplectic groups.

Contents

1	Introduction	2
1.1	The Statement of Tokuyama's Formula	3
2	Review of Existing Proofs	6
2.1	Direct Proof by Daniel Bump	6
2.1.1	Proof Idea	6
2.1.2	Recursion Relations	7
2.1.3	Proving Tokuyama's Formula	10
2.2	Combinatorial Proof by Soichi Okada	11
2.2.1	Prerequisites from Graph Theory	11
2.2.2	Shifted Plane Partitions	12
2.2.3	Lattice Paths and Generating Functions	13
2.2.4	Lattice Paths and Connections to Plane Partitions	14
2.2.5	A Proof of Tokuyama's Formula by Plane Partitions	16
2.3	Lattice Models Proof by Brubaker, Bump, Friedberg	19
3	New Proofs	23
3.1	New Direct Proof	23
3.2	New Combinatorial Proof of Tokuyama's formula	27
3.2.1	Primed Strict GT-patterns	27
3.2.2	A Proof by a Pairing Algorithm	28
4	Symplectic Tokuyama's Formula	31
4.1	The Statement of the Symplectic Tokuyama's Formula	31
4.2	Review of Existing Methods	33
4.3	The Direct Method for the Symplectic Tokuyama Formula	35
4.4	The Combinatorial Method for the Symplectic Tokuyama Formula	38
4.4.1	The Factor $1 + tz_1z_2$	40
4.4.2	Remarks on the Combinatorial Method	42
5	Conclusion	44
5.1	Future Directions	44
5.2	Acknowledgments	44

1 Introduction

Tokuyama’s formula is a powerful result relating combinatorics to representation theory. It gives us a combinatorial evaluation of the spherical Whittaker function for the general linear group $GL(n)$, which is an important function having applications in number theory, geometry, representation theory, and other branches of mathematics. More precisely, as depicted in figure 1, it gives an explicit combinatorial evaluation of the well-known Casselman-Shalika expression for the spherical Whittaker function, as a sum over weights of a certain set of combinatorial objects called Gelfand-Tsetlin patterns. We can thus translate between the languages of representation theory, special functions, and combinatorics using these equivalences.

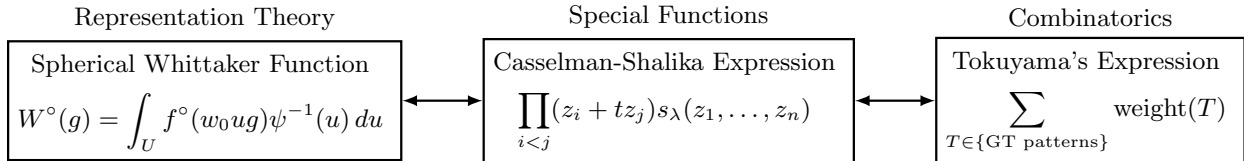

Figure 1: Equivalent expressions with respect to GL_n , which has characters s_λ

Whittaker functions are not unique to $GL(n)$, however. Other reductive groups, such as symplectic groups $Sp(2n)$ and orthogonal groups $O(n)$, over local fields have spherical Whittaker functions, for which we have an interest in obtaining explicit expressions. We know by Casselman-Shalika’s formula that we can give an evaluation of the spherical Whittaker function in terms of special functions, as shown in figure 2, but little is known in general how to translate this further into an explicit, Tokuyama-like combinatorial evaluation.

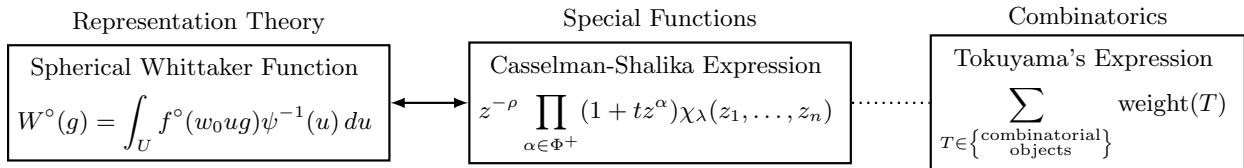

Figure 2: Equivalent expressions with respect to a reductive group G , which has characters χ_λ

Besides giving us an explicit evaluation of the spherical Whittaker function for $GL(n)$, Tokuyama’s formula also specializes to many well-known identities from the representation theory of $GL(n)$ including Jacobi’s bi-alternant formula, Gelfand parametrization, and Stanley’s evaluation of values of Hall-Littlewood polynomials. This gives another reason for us to be interested in finding Tokuyama-like expressions for other reductive groups: specializing the parameters in a Tokuyama-like formula can yield insightful identities in the representation theory of reductive groups.

Generalizing Tokuyama’s formula to other reductive groups is an active area of research. In 2009, Ivanov proved Tokuyama’s formula for symplectic groups using solvable lattice models in [Iva12], and in 2014, Friedberg and Zhang found a Tokuyama-like expression for orthogonal groups in [FZ16], though the formula isn’t exactly what we desire. Our goal in this project was to find novel proofs of Tokuyama’s formula for $GL(n)$ that would be amenable to generalization. In this vein, we have devised two novel proofs of Tokuyama’s formula, which we have made progress toward adapting to the symplectic groups $Sp(2n)$. In Section 3, we will describe our new proofs of Tokuyama’s formula for $GL(n)$ —one direct and one combinatorial—which both rely on a similar idea but executed differently. Namely, our idea involves pairing Gelfand-Tsetlin patterns. However, the approach is local in the case of the direct proof, pairing only partial patterns, while the approach is global in the case of the combinatorial proof, pairing complete patterns. We then discuss our progress in generalizing these proofs to the symplectic groups $Sp(2n)$ in Section 4.

Before discussing our new proofs, we will introduce the main objects of study in Section 1.1. There we will define the combinatorial objects that are used in Tokuyama’s formula for $GL(n)$, and we will state

Tokuyama’s formula and some of its consequences. After this, we will examine three existing proofs of Tokuyama’s formula: a direct proof by Bump [Nap21], a combinatorial proof by Okada [Oka90], and a proof by Brubaker, Bump, and Friedberg [BBF10] that uses lattice models. These overviews appear in Section 2. Finally, we will conclude in Section 5 with future directions of research and acknowledgments.

1.1 The Statement of Tokuyama’s Formula

The main objects of study regarding Tokuyama’s formula all make use of a fundamental combinatorial object called a partition. Here, we shall define what a partition is and some of the common properties which are used in the rest of the paper.

Definition 1.1 (Partitions). A **partition** $\lambda = (\lambda_1, \lambda_2, \dots)$ is any (finite or infinite) sequence of non-negative integers arranged in descending order which contains only finitely many non-zero terms.

For convenience we consider any two sequences which differ only by a string of trailing zeroes at the end to be indistinguishable. We often represent partitions visually using what are often called (Young) diagrams.

Definition 1.2 (The Diagram of a Partition). The **(Young) diagram** of a partition λ is an array of unit squares, denoted $Y(\lambda)$, that represents the partition as follows: there are λ_1 unit squares in the top row, λ_2 unit squares in the second row, and so on. The partition λ is said to be the **shape** of the diagram $Y(\lambda)$.

For the rest of the paper, we will refer to the (Young) diagram of a partition as its diagram. We present now an example of a partition with its corresponding diagram.

Example 1.0.1. Consider the partition $\lambda = (5, 4, 4, 1)$. Its diagram $Y(\lambda)$ is drawn as follows:

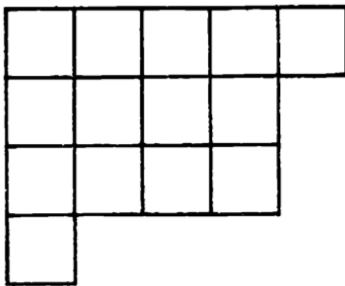

Figure 3: The diagram $Y(\lambda)$ for the partition $\lambda = (5, 4, 4, 1)$.

There is a closely related way to represent partitions visually known as shifted diagrams. Depending on the context, it is sometimes more enlightening or convenient to work with shifted diagrams instead of (Young) diagrams, though they represent the same data.

Definition 1.3 (Shifted Diagram). Suppose that λ is a partition with diagram $Y(\lambda)$. Then the **shifted diagram** of λ , denoted $S(\lambda)$, is given by shifting the i -th row of $Y(\lambda)$ to the right by $(i - 1)$ squares.

Example 1.0.2. The partition $\lambda = (4, 3, 1)$ has diagram $Y(\lambda)$ and shifted diagram $S(\lambda)$ given by

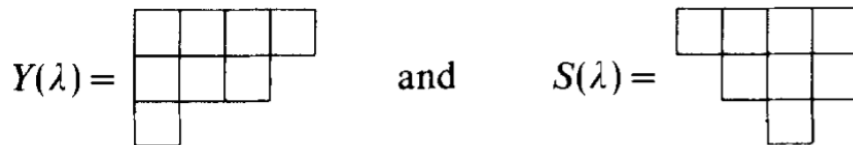

Figure 4: The diagram and shifted diagram of the partition $\lambda = (4, 3, 1)$.

We shall now introduce the language used to describe the basic properties of partitions.

Definition 1.4 (Definitions Related to Partitions). *Given a partition $\lambda = (\lambda_1, \lambda_2, \dots)$,*

- (a) *The nonzero λ_i are called the **parts** of λ .*
- (b) *The number of parts is called the **length** of λ and is denoted $\ell(\lambda)$.*
- (c) *The sum of all the parts is called the **weight** of λ and is denoted $|\lambda|$.*
- (d) *If $|\lambda| = n$, we say that λ is a **partition of n** .*
- (e) *The set of all partitions of n is denoted \mathcal{P}_n , and the set of all partitions is denoted \mathcal{P} .*

Partitions also may be combined with algebraic operations. In this article, we use only addition and subtraction, which are done componentwise: if $\lambda = (\lambda_1, \lambda_2, \dots, \lambda_n)$ and $\mu = (\mu_1, \mu_2, \dots, \mu_n)$, then their sum is $\lambda + \mu = (\lambda_1 + \mu_1, \lambda_2 + \mu_2, \dots, \lambda_n + \mu_n)$, and similarly for subtraction.

An important partition which we define is the “smallest” strictly decreasing partition of length n , which we write as $\rho_n = (n-1, n-2, \dots, 1, 0)$. One important use of partitions is to index the irreducible characters of the general linear group $\text{GL}(n)$, which are the Schur polynomials. The definition of Schur polynomials we will use in this paper is that given by Macdonald [Mac95], who defines Schur polynomials using the antisymmetric polynomials $a_{\lambda+\rho_n}(z_1, \dots, z_n)$ and Jacobi’s bi-alternant formula.

Definition 1.5 (Antisymmetric Polynomials $a_{\lambda+\rho_n}$). *Let λ be a partition of length $\ell(\lambda) \leq n$. We define the **antisymmetric polynomial** $a_{\lambda+\rho_n}$ **corresponding to λ** to be the polynomial given by*

$$a_{\lambda+\rho_n}(z_1, \dots, z_n) = \sum_{\sigma \in \mathcal{S}_n} \text{sgn}(\sigma) z^{\sigma(\lambda+\rho_n)} = \det \begin{vmatrix} z_1^{\lambda_1+n-1} & z_1^{\lambda_2+n-2} & \dots & z_1^{\lambda_n} \\ z_2^{\lambda_1+n-1} & z_2^{\lambda_2+n-2} & \dots & z_2^{\lambda_n} \\ \vdots & \vdots & \ddots & \vdots \\ z_n^{\lambda_1+n-1} & z_n^{\lambda_2+n-2} & \dots & z_n^{\lambda_n} \end{vmatrix}.$$

Note that when $\lambda = (0, 0, \dots, 0)$, the antisymmetric polynomial $a_{\lambda+\rho_n} = a_{\rho_n}$ is simply the Vandermonde determinant in n indeterminates.

The antisymmetric polynomials $a_{\lambda+\rho_n}$ are now used to define the Schur polynomials.

Definition 1.6 (Schur Polynomials). *Let λ be a partition of length $\ell(\lambda) \leq n$. We define the **Schur polynomial** s_λ to be the polynomial given by*

$$s_\lambda(z_1, \dots, z_n) = \frac{a_{\lambda+\rho_n}(z_1, \dots, z_n)}{a_{\rho_n}(z_1, \dots, z_n)}, \quad (1)$$

where $a_{\lambda+\rho_n}$ is the antisymmetric polynomial corresponding to $\lambda + \rho_n$.

The formula given in (1) is called Jacobi’s bi-alternant formula for the Schur polynomials.

Having now defined partitions and Schur polynomials, we can commence with the main combinatorial object that Tokuyama’s formula concerns. Namely, we define a triangular array of numbers called a Gelfand-Tsetlin pattern.

Definition 1.7 (Gelfand-Tsetlin Pattern). *A **Gelfand-Tsetlin (GT) pattern** is a triangular array of non-negative integers*

$$\begin{bmatrix} a_{1,1} & & a_{1,2} & & \dots & & a_{1,n} \\ & a_{2,1} & & a_{2,2} & & \dots & & a_{2,n} \\ & & a_{3,1} & & a_{3,2} & & a_{3,3} & & \dots & & a_{3,n} \\ & & & a_{4,1} & & a_{4,2} & & a_{4,3} & & a_{4,4} & & \dots & & a_{4,n} \\ & & & & a_{5,1} & & a_{5,2} & & a_{5,3} & & a_{5,4} & & a_{5,5} & & \dots & & a_{5,n} \\ & & & & & a_{6,1} & & a_{6,2} & & a_{6,3} & & a_{6,4} & & a_{6,5} & & a_{6,6} & & \dots & & a_{6,n} \\ & & & & & & a_{7,1} & & a_{7,2} & & a_{7,3} & & a_{7,4} & & a_{7,5} & & a_{7,6} & & a_{7,7} & & \dots & & a_{7,n} \\ & & & & & & & a_{8,1} & & a_{8,2} & & a_{8,3} & & a_{8,4} & & a_{8,5} & & a_{8,6} & & a_{8,7} & & a_{8,8} & & \dots & & a_{8,n} \\ & & & & & & & & a_{9,1} & & a_{9,2} & & a_{9,3} & & a_{9,4} & & a_{9,5} & & a_{9,6} & & a_{9,7} & & a_{9,8} & & a_{9,9} & & \dots & & a_{9,n} \end{bmatrix}$$

satisfying $a_{i,j} \geq a_{i+1,j+1} \geq a_{i,j+1}$ (called the **in-betweenness condition**). The set of Gelfand-Tsetlin patterns with top row $\lambda = (a_{1,1}, \dots, a_{1,n})$ is denoted $\text{GT}(\lambda)$.

We will see five proofs of this theorem throughout the paper. For now, let us consider a small example that demonstrates the calculations given by (2).

Example 1.0.4. Let $\lambda = (a, 0)$ so that $\lambda + \rho_2 = (a + 1, 0)$. The strict GT-patterns with this top row are:

$$\begin{array}{cccc} \begin{bmatrix} a+1 & & 0 \\ & a+1 & \\ & & \end{bmatrix} & \begin{bmatrix} a+1 & & 0 \\ & a & \\ & & \end{bmatrix} & \cdots & \begin{bmatrix} a+1 & & 0 \\ & 1 & \\ & & \end{bmatrix} & \begin{bmatrix} a+1 & & 0 \\ & & 0 \\ & & \end{bmatrix} \\ tz_2^{a+1} & (1+t)z_1z_2^a & \cdots & (1+t)z_1^az_2 & z_1^{a+1}. \end{array}$$

The left side of Tokuyama's formula (2) is thus computed as

$$\begin{aligned} \sum_{T \in \text{SGT}(\lambda + \rho_2)} (t+1)^{g(T)} t^{l(T)} z_1^{d_1(T)} z_2^{d_2(T)} &= tz_2^{a+1} + (t+1)z_1z_2^a + \cdots + (1+t)z_1^az_2 + z_1^{a+1} \\ &= (z_1 + tz_2)(z_1^a + z_1^{a-1}z_2 + \cdots + z_1z_2^{a-1} + z_2^a). \end{aligned}$$

Notice that $s_{(a,0)}(z_1, z_2) = z_1^a + z_1^{a-1}z_2 + \cdots + z_1z_2^{a-1} + z_2^a$, so this is indeed the result predicted by Tokuyama's formula.

2 Review of Existing Proofs

We begin by considering three existing proofs of Tokuyama's formula.

2.1 Direct Proof by Daniel Bump

In 2021, Slava Naprienko published an online post to Thuses containing a direct proof of Tokuyama's formula created by Dan Bump. In this section, we will examine Bump's direct proof.

2.1.1 Proof Idea

The idea of the proof is to use induction on the length of λ . Such an approach is natural, as the structure of Gelfand-Tsetlin patterns is inherently inductive, as seen in figure 5.

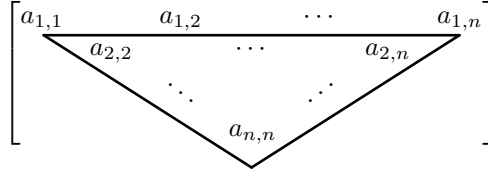

Figure 5: Rows $2, \dots, n$ of a Gelfand-Tsetlin pattern themselves form a Gelfand-Tsetlin pattern, but whose top row has length $n - 1$.

With this in mind, we define n -variate functions L and R parametrized by a partition λ of length n and a value t , where L is the left side of Tokuyama's formula (2) and R is the right side of (2):

$$\begin{aligned} L(\lambda; t; z_1, \dots, z_n) &:= \sum_{T \in \text{SGT}(\lambda + \rho_n)} \left((t+1)^{g(T)} t^{l(T)} \prod_{i=1}^n z_i^{d_i(T)} \right) \\ R(\lambda; t; z_1, \dots, z_n) &:= \left(\prod_{1 \leq i < j \leq n} (z_i + tz_j) \right) s_\lambda(z_1, \dots, z_n). \end{aligned} \tag{3}$$

We then proceed by induction on n to show that $L = R$. It is easy to verify the base case $n = 1$. In the inductive step, we seek to manipulate L and R to get recursion relations

$$\begin{aligned} L(\lambda; t; z_1, \dots, z_n) &= \sum_{\nu} a_{\nu} L(\nu; t; z_2, \dots, z_n) \\ R(\lambda; t; z_1, \dots, z_n) &= \sum_{\nu} b_{\nu} R(\nu; t; z_2, \dots, z_n), \end{aligned} \tag{4}$$

where each $\nu + \rho_{n-1}$ is a valid second row in a strict Gelfand-Tsetlin pattern with $\lambda + \rho_n$ as its top row, and a_{ν} and b_{ν} are some coefficients. With L and R written in these forms, we can appeal to the inductive hypothesis to identify the factors $L(\nu; \cdot)$ and $R(\nu; \cdot)$ which appear in the sums, and we need only “meet in the middle” by showing that the coefficients a_{ν} and b_{ν} are equal for each ν .

Before proceeding with the details of the proof, we present here a convenient equivalent condition for $\nu + \rho_{n-1}$ to be a valid second row in a Gelfand-Tsetlin pattern with $\lambda + \rho_n$.

Remark 2.1 (Second Row Condition). *Let λ and ν be partitions with lengths $\ell(\lambda) \leq n$ and $\ell(\nu) \leq n - 1$. Then $\nu + \rho_{n-1}$ is a valid second row in a strict Gelfand-Tsetlin pattern which has top row $\lambda + \rho_n$ if and only if $\nu + \rho_{n-1}$ interleaves $\lambda + \rho_n$, i.e., $\lambda_1 \geq \nu_1 \geq \dots \geq \nu_{n-1} \geq \lambda_n$.*

Proof. This is the in-betweenness condition for Gelfand-Tsetlin patterns. \square

2.1.2 Recursion Relations

We first show a recursion relation of the form in (4) for L . This is a reasonably straightforward endeavor, as L is a sum over Gelfand-Tsetlin patterns by definition (3), and we have seen that Gelfand-Tsetlin patterns are amenable to induction. We introduce some notation to simplify the statement of the recursion relation.

Notation 2.0.1 (Row Contributions). *Let T be a Gelfand-Tsetlin pattern which has top row $\lambda + \rho_n$ and second row $\nu + \rho_{n-1}$. Then we denote the contributions of the second row to the weight of T as follows:*

- The number of left-leaning terms in the second row is denoted $l(\lambda, \nu)$;
- The number of generic terms in the second row is denoted $g(\lambda, \nu)$;
- The difference of the sum of the entries in the first row and the sum of the entries in the second row is denoted $m_1(\lambda, \nu)$, that is,

$$m_1(\lambda, \nu) = \left(\sum_{i=1}^n \lambda_i + n - i \right) - \left(\sum_{i=1}^{n-1} \nu_i + (n-1) - i \right).$$

We now state the recursion relation for L .

Lemma 2.0.1 (Left Side Recursion Relation). *The left side L of Tokuyama’s formula, defined in (3), has the recursion relation*

$$L(\lambda; t; z_1, \dots, z_n) = \sum_{\nu} (t+1)^{g(\lambda, \nu)} t^{l(\lambda, \nu)} z_1^{m_1(\lambda, \nu)} L(\nu; t; z_2, \dots, z_n), \tag{5}$$

where the sum is over partitions ν such that $\nu + \rho_{n-1}$ interleaves $\lambda + \rho_n$.

Proof. Observe that for each such ν and each $T \in \text{SGT}(\lambda + \rho_n)$ having $\nu + \rho_{n-1}$ as a second row (recall Remark 2.1), we have that $g(T) = g(\lambda, \nu)g(T')$, where T' is the strict Gelfand-Tsetlin pattern obtained by removing the first row of T . Analogous decompositions may be written for $l(T)$ and $m_1(T)$. Hence, we may write L as

$$\begin{aligned} L(\lambda; t; z_1, \dots, z_n) &= \sum_{T \in \text{SGT}(\lambda + \rho_n)} \left((t+1)^{g(T)} t^{l(T)} \prod_{i=1}^n z_i^{d_i(T)} \right) \\ &= \sum_{\nu} \left[(t+1)^{g(\lambda, \nu)} t^{l(\lambda, \nu)} z_1^{m_1(\lambda, \nu)} \sum_{T' \in \text{SGT}(\nu + \rho_{n-1})} \left((t+1)^{g(T')} t^{l(T')} \prod_{i=2}^n z_i^{d_i(T')} \right) \right] \\ &= \sum_{\nu} (t+1)^{g(\lambda, \nu)} t^{l(\lambda, \nu)} z_1^{m_1(\lambda, \nu)} L(\nu; t; z_2, \dots, z_n), \end{aligned}$$

which is the desired recursion relation. \square

We now wish to find a similar recursion relation for R . Doing so requires some tools from the theory of symmetric functions, namely, Pieri's formula and branching rules for Schur polynomials. We state these results with reference to proofs in literature.

Lemma 2.0.2 (Pieri's formula). *Let $\mu = (\mu_1, \mu_2, \dots, \mu_n)$ be a partition and $k \geq 1$ and integer. Then the Schur polynomial s_μ satisfies the relation*

$$e_k(z_1, \dots, z_n) s_\mu(z_1, \dots, z_n) = \sum_{\nu} s_\nu(z_1, \dots, z_n) \quad (6)$$

where e_k is the k -th elementary symmetric polynomial and the sum on the right is over partitions ν such that $\nu - \mu$ is a k -vertical strip.

Proof. See (5.17) in Chapter I of [Mac95]. \square

Lemma 2.0.3 (Branching Rules for Schur Polynomials). *Let λ be a partition of length n . Then*

$$s_\lambda(z_1, z_2, \dots, z_n) = \sum_{\mu} z_1^{|\lambda - \mu|} s_\mu(z_2, \dots, z_n), \quad (7)$$

where the sum is over partitions μ of length $n - 1$ which interleave λ .

Proof. See Proposition 10.1 of [Pro94]. \square

With these tools, we are ready to state and prove the recursion relation for R .

Lemma 2.0.4 (Right Side Recursion Relation). *The right side R of Tokuyama's formula, defined in (3), has the recursion relation*

$$R(\lambda; t; z_1, \dots, z_n) = \sum_{\nu} \left(\sum_{\mu} t^{|\nu - \mu|} z_1^{m_1(\lambda, \nu)} \right) R(\nu; t; z_2, \dots, z_n), \quad (8)$$

where ν ranges over partitions such that $\nu + \rho_{n-1}$ interleaves $\lambda + \rho_n$; and μ ranges over partitions such that $\mu_i \leq \nu_i$ for each i , and the skew diagram $\nu - \mu$ is a vertical strip.

Proof. We begin by pulling out a factor of $\prod_{1 < j} (z_1 + tz_j)$ from the product $\prod_{i < j} (z_i + tz_j)$ in (3):

$$\begin{aligned} R(\lambda; t; z_1, \dots, z_n) &= \left(\prod_{1 \leq i < j \leq n} (z_i + tz_j) \right) s_\lambda(z_1, \dots, z_n) \\ &= \left(\prod_{1 < j \leq n} (z_1 + tz_j) \right) \left(\prod_{1 < i < j \leq n} (z_i + tz_j) \right) s_\lambda(z_1, \dots, z_n). \end{aligned} \quad (9)$$

We now apply (7) to the Schur polynomial in (9) so that we may obtain a Schur polynomial in the $n - 1$ indeterminates z_2, \dots, z_n :

$$s_\lambda(z_1, \dots, z_n) = \sum_{\mu} z_1^{|\lambda - \mu|} s_\mu(z_2, \dots, z_n)$$

where partitions μ of length $n - 1$ interleave with λ . Hence, (9) becomes

$$\begin{aligned} &\left(\prod_{1 < j \leq n} (z_1 + tz_j) \right) \left(\prod_{1 < i < j \leq n} (z_i + tz_j) \right) s_\lambda(z_1, \dots, z_n) \\ &= \left(\prod_{1 < j \leq n} (z_1 + tz_j) \right) \left(\prod_{1 < i < j \leq n} (z_i + tz_j) \right) \sum_{\mu} z_1^{|\lambda - \mu|} s_\mu(z_2, \dots, z_n). \end{aligned} \quad (10)$$

We wish now to refactor the sum so that it is indexed by partitions ν which give us second rows $\nu + \rho_{n-1}$ for our Gelfand-Tsetlin patterns, and so that the Schur polynomial has a coefficient of 1. This way, we can effect the expression for R in $n - 1$ indeterminates. We begin down this path by expanding the product $\prod_{1 < j \leq n} (z_1 + tz_j)$ in terms of elementary symmetric functions:

$$\prod_{1 < j \leq n} (z_1 + tz_j) = z_1^{n-1} \prod_{1 < j \leq n} (1 + (tz_1^{-1})z_j) = z_1^{n-1} \sum_{k=0}^{n-1} t^k z_1^{-k} e_k(z_2, \dots, z_n),$$

where e_k is the k -th elementary symmetric polynomial. We can now substitute this into (10) and rearrange to get

$$\begin{aligned} & \left(\prod_{1 < j \leq n} (z_1 + tz_j) \right) \left(\prod_{1 < i < j \leq n} (z_i + tz_j) \right) \sum_{\mu} z_1^{|\lambda - \mu|} s_{\mu}(z_2, \dots, z_n) \\ &= \left(z_1^{n-1} \sum_{k=0}^{n-1} t^k z_1^{-k} e_k(z_2, \dots, z_n) \right) \left(\prod_{1 < i < j \leq n} (z_i + tz_j) \right) \sum_{\mu} z_1^{|\lambda - \mu|} s_{\mu}(z_2, \dots, z_n) \\ &= \sum_{k, \mu} \left(t^k z_1^{|\lambda - \mu| - k + n - 1} \prod_{1 < i < j \leq n} (z_i + tz_j) e_k(z_2, \dots, z_n) s_{\mu}(z_2, \dots, z_n) \right). \end{aligned} \quad (11)$$

We now combine the product $e_k s_{\mu}$ in (11) by using (6), thus obtaining

$$\begin{aligned} R(\lambda; t; z_1, \dots, z_n) &= \sum_{k, \mu} \left(t^k z_1^{|\lambda - \mu| - k + n - 1} \prod_{1 < i < j \leq n} (z_i + tz_j) e_k(z_2, \dots, z_n) s_{\mu}(z_2, \dots, z_n) \right) \\ &= \sum_{k, \mu, \nu} \left(t^k z_1^{|\lambda - \mu| - k + n - 1} \prod_{1 < i < j} (z_i + tz_j) s_{\nu}(z_2, \dots, z_n) \right) \\ &= \sum_{k, \mu, \nu} \left(t^k z_1^{|\lambda - \mu| - k + n - 1} R(\nu; t; z_2, \dots, z_n) \right), \end{aligned} \quad (12)$$

where ν ranges over partitions containing μ such that $\nu - \mu$ is a k -vertical strip.

We now seek to eliminate the dependence on k . Since $\nu - \mu$ is a k -vertical strip, we have by definition that $k = |\nu - \mu|$. Also, $|\lambda - \mu| - |\nu - \mu| = \sum_i (\lambda_i - \mu_i) - (\nu_i - \mu_i) = |\lambda - \nu|$. Hence, we may replace the exponents on t and z_1 in (12) to obtain

$$\begin{aligned} R(\lambda; t; z_1, \dots, z_n) &= \sum_{k, \mu, \nu} \left(t^k z_1^{|\lambda - \mu| - k + n - 1} R(\nu; t; z_2, \dots, z_n) \right) \\ &= \sum_{\mu, \nu} \left(t^{|\nu - \mu|} z_1^{|\lambda - \nu| + n - 1} R(\nu; t; z_2, \dots, z_n) \right), \end{aligned} \quad (13)$$

where now ν ranges over the partitions which make $\nu - \mu$ a vertical strip of any length.

We conclude by swapping the order of summation so that we instead sum first over partitions ν such that $\nu + \rho_{n-1}$ interleaves $\lambda + \rho_n$, then sum over $\mu \subset \nu$ such that $\nu - \mu$ is a vertical strip. To make this change, first note that the conditions imposed on μ and ν in (13) imply that $\nu + \rho_{n-1}$ interleaves $\lambda + \rho_n$. To see this, we show that

$$\lambda_i + 1 \geq \nu_i \geq \lambda_{i+1} \quad (14)$$

so that $\lambda_i + n - i \geq \nu_i + (n - 1) - i \geq \lambda_{i+1} + n - (i + 1)$, which is exactly the statement $(\lambda + \rho_n)_i \geq (\nu + \rho_{n-1})_i \geq (\lambda + \rho_n)_{i+1}$. Since μ interleaves λ , we have that $\lambda_i \geq \mu_i \geq \lambda_{i+1}$. Since $\nu - \mu$ is a vertical strip, $\mu_i = \nu_i$ or $\mu_i = \nu_i - 1$. Hence, $\lambda_i + 1 \geq \mu_i + 1 \geq \nu_i$ and $\nu_i \geq \mu_i \geq \lambda_{i+1}$.

Conversely, if $\nu + \rho_{n-1}$ interleaves $\lambda + \rho_n$, and $\mu \subset \nu$ is such that $\nu - \mu$ is a vertical strip, then we must check that $\lambda_i \geq \mu_i \geq \lambda_{i+1}$ for each i . But this is simply the reverse of the above steps for the forward direction. Hence, we may swap the order of summation in (13) to obtain

$$\begin{aligned} R(\lambda; t; z_1, \dots, z_n) &= \sum_{\mu, \nu} \left(t^{|\nu-\mu|} z_1^{|\lambda-\nu|+n-1} R(\nu; t; z_2, \dots, z_n) \right) \\ &= \sum_{\nu} \left[\left(\sum_{\mu} t^{|\nu-\mu|} \right) z_1^{m_1(\lambda, \nu)} R(\nu; t; z_2, \dots, z_n) \right], \end{aligned} \quad (15)$$

where ν ranges over partitions such that $\nu + \rho_{n-1}$ interleaves $\lambda + \rho_n$, and $\mu \subset \nu$ ranges over partitions such that $\nu - \mu$ is a vertical strip. This is the desired recursion relation. \square

2.1.3 Proving Tokuyama's Formula

With both L and R written as recursion relations of the form presented in (4), we can now prove the induction step by establishing equality between the coefficients, and thus prove Tokuyama's formula.

Proof of Tokuyama's formula (2). With L and R defined as in (3), we proceed by induction on the length of λ to show that $L = R$. The base case $n = 1$ is easy to check. Assume now that $L = R$ for $n - 1$ indeterminates. By (5) and (8), we have that

$$\begin{aligned} L(\lambda; t; z_1, \dots, z_n) &= \sum_{\nu} (t+1)^{g(\lambda, \nu)} t^{l(\lambda, \nu)} z_1^{m_1(\lambda, \nu)} L(\nu; t; z_2, \dots, z_n) \\ R(\lambda; t; z_1, \dots, z_n) &= \sum_{\nu} \left(\sum_{\mu} t^{|\nu-\mu|} z_1^{m_1(\lambda, \nu)} \right) R(\nu; t; z_2, \dots, z_n), \end{aligned}$$

where ν ranges over partitions such that $\nu + \rho_{n-1}$ interleaves $\lambda + \rho_n$, and $\mu \subset \nu$ ranges over partitions such that $\nu - \mu$ is a vertical strip. It remains to demonstrate that the coefficients in the recursion relations for L and R are equal, that is,

$$(1+t)^{g(\lambda, \nu)} t^{l(\lambda, \nu)} z_1^{m_1(\lambda, \nu)} = \left(\sum_{\mu} t^{|\nu-\mu|} \right) z_1^{m_1(\lambda, \nu)},$$

since we conclude by the inductive hypothesis that $L(\nu; \cdot) = R(\nu; \cdot)$ for each ν in the sums.

We see immediately that $z_1^{m_1(\lambda, \nu)}$ appears in both the coefficients, so we need only check that for each fixed ν ,

$$(1+t)^{g(\lambda, \nu)} t^{l(\lambda, \nu)} = \sum_{\mu} t^{|\nu-\mu|}, \quad (16)$$

where μ interleaves λ and $\nu - \mu$ is a vertical strip. Define now

$$R_i = \{r \in \mathbb{N} \mid \exists \mu \text{ interleaving } \lambda \text{ with } \mu_i = r\}.$$

Then we can write the right side of (16) as

$$\sum_{\mu} t^{|\nu-\mu|} = \sum_{\mu} \left(\prod_{i=1}^{n-1} t^{\nu_i - \mu_i} \right) = \prod_{i=1}^{n-1} \left(\sum_{r \in R_i} t^{\nu_i - r} \right). \quad (17)$$

We can describe the values in each R_i explicitly by finding the possible values for each μ_i . We do so by finding the values of ν_i , from which we can recover μ_i since $\nu - \mu$ is a vertical strip. As described previously, we know that the constraints placed on ν and μ imply that $\nu + \rho_{n-1}$ interleaves $\lambda + \rho_n$. So, we may consider a strict Gelfand-Tsetlin pattern T having top row $\lambda + \rho_n$ and second row $\nu + \rho_{n-1}$ and apply (14) to obtain the possible values for ν_i (and thus the possible values for μ_i).

If $\nu_i = \lambda_{i+1}$ then the pattern T has a right-learning entry in the i -th position; if $\nu_i = \lambda_i + 1$, then the pattern has a left-learning entry; otherwise, the entry is generic. By the definition of vertical strip, we have

that, for each i , either $\mu_i = \nu_i$ or $\mu_i = \nu_i - 1$. In the left-leaning case, μ_i cannot be equal to ν_i since that would imply that $\mu_i > \lambda_i$, which we cannot have since μ interleaves λ . So, we must have $\mu_i = \nu_i - 1$ in the left-leaning case. Similarly, in the right-leaning case, μ_i cannot be equal to $\nu_i + 1$ since that would imply that $\mu_i < \lambda_{i+1}$. Hence, we have that $\mu_i = \nu_i$ in the right-leaning case. In the generic case, we see that μ_i can take either value ν_i or $\nu_i - 1$ without contradiction. Hence, we can expand each factor of (17) as

$$\sum_{r \in R_i} t^{\nu_i - r} = \begin{cases} t, & \text{in the left-leaning case} \\ 1, & \text{in the right-leaning case} \\ 1 + t, & \text{in the generic case} \end{cases}.$$

This gives us precisely (17). So, we conclude that

$$\begin{aligned} L(\lambda; t; z_1, \dots, z_n) &= \sum_{T \in \text{SGT}(\lambda + \rho_n)} \left((t+1)^{g(T)} t^{l(T)} \prod_{i=1}^n z_i^{d_i(T)} \right) \\ &= \left(\prod_{1 \leq i < j \leq n} (z_i + tz_j) \right) s_\lambda(z_1, \dots, z_n) \\ &= R(\lambda; t; z_1, \dots, z_n), \end{aligned}$$

and so Tokuyama's formula (2) holds □

2.2 Combinatorial Proof by Soichi Okada

2.2.1 Prerequisites from Graph Theory

Definition 2.1 (Locally Finite Graph). *A locally finite graph is a graph with a (possibly infinite) set of vertices such that the set of edges of any single vertex is finite.*

Definition 2.2 (Acyclic Graph). *An acyclic directed graph is a directed graph with no cycles – i.e., a graph with no sequence of multiple vertices v_0, v_1, \dots, v_n with $v_0 = v_n$ and an edge from v_i to v_{i+1} for each i .*

The most important example of a locally finite (but infinite) acyclic graph is probably the following:

Example 2.1.1 (Acyclic Planes). *Consider the graph G with vertices \mathbb{Z}^2 and directed edges $(x, y) \rightarrow (x, y+1)$ and $(x, y) \rightarrow (x+1, y)$ for each integer x and y . In particular, G is a locally finite directed acyclic graph and we call it the acyclic plane.*

Definition 2.3 (Path System). *Given “sources” a_1, \dots, a_n and “sinks” b_1, \dots, b_n (both sets of distinguished vertices) in a locally finite directed graph G , a path system \mathcal{P} is an n -tuple of paths, sending each source to a distinct sink. Such a path system has an associated permutation: the permutation of $\{1, \dots, n\}$ corresponding to which source goes to which sink. We denote this permutation $\sigma(\mathcal{P})$.*

Definition 2.4 (Non-Intersecting Path System). *A path system is said to be a non-intersecting path system if no two distinct paths share a vertex.*

Lemma 2.0.5 (The Lindström-Gessel-Viennot Lemma). *Consider a locally finite acyclic directed graph G with sources a_1, \dots, a_n and sinks b_1, \dots, b_n . Define a weight on each edge e in G , denoted $\omega(e)$, and define the weight of a path P in G to be the product of the weights of the edges in P , denoted $\omega(P)$. For any two vertices a and b , define $e(a, b)$ to be the sum of the weights of the paths between a and b .*

Also let the weight of a path system \mathcal{P} , denoted by $\omega(\mathcal{P})$, be $\prod_{P \in \mathcal{P}} \omega(P)$. Finally, let M be the matrix whose i, j -entry is $e(a_i, b_j)$. Then, if \mathcal{N} is the set of all non-intersecting path systems in G ,

$$\det M = \sum_{\mathcal{P} \in \mathcal{N}} \text{sign}(\sigma(\mathcal{P})) \omega(\mathcal{P})$$

Corollary 2.0.1. *If the only possible permutation of a non-intersecting path system \mathcal{P} is the identity permutation, then $\det M = \sum_{\mathcal{P} \in \mathcal{N}} \prod_{P \in \mathcal{P}} \omega(P)$.*

Proof. Follows trivially from Lemma 2.0.5. \square

Corollary 2.0.2. *If the weight function is 1 (that is, the graph is unweighted) and furthermore the only possible permutation of a non-intersecting path system is the identity, then $\det M$ is the number of non-intersecting path systems in G .*

Proof. Follows trivially from Corollary 2.0.1. \square

For such a complex theorem to state, the proof of the Lindström-Gessel-Viennot Lemma is remarkably simple. Intuitively, we start with the Leibniz formula for determinants, and then just need to define an involution on the path systems which fixes the non-intersecting path systems but reverses the sign of the permutation of the intersecting path systems (so they all cancel out except the non-intersecting path systems).

Proof. Recall the Leibniz formula for determinants: if A is a matrix with i, j entry $a_{i,j}$, then

$$\det(A) = \sum_{\sigma \in S_n} \text{sign}(\sigma) \prod_{i=1}^n a_{i, \sigma(i)}$$

In particular, for our matrix M , we see that:

$$\det(M) = \sum_{\sigma \in S_n} \text{sign}(\sigma) \prod_{i=1}^n e(a_i, b_{\sigma(i)}) = \sum_{\sigma \in S_n} \text{sign}(\sigma) \sum \{\omega(\mathcal{P}) : \mathcal{P} \text{ a path system with } \sigma(\mathcal{P}) = \sigma\}$$

Now, if \mathcal{S} is the set of all path systems in G , then the above sum (and therefore $\det M$) is equal to:

$$\sum_{\mathcal{P} \in \mathcal{S}} \text{sign}(\sigma(\mathcal{P})) \omega(\mathcal{P})$$

Now we seek to prove that the given sum over all $\mathcal{P} \in \mathcal{S} \setminus \mathcal{N}$ is 0. To do this, consider an involution on the intersecting path systems (i.e. on $\mathcal{S} \setminus \mathcal{N}$) defined so:

1. Let i be the smallest index such that the path from a_i intersects another path and let j be the largest index such that the path from a_j intersects the path from a_i .
2. Let v be the vertex which is the first intersection between the paths from a_i and a_j .
3. Swap the two paths (the path from a_i and the path from a_j) *after* v , thereby negating the sign of the path system.

Clearly this is an involution on $\mathcal{S} \setminus \mathcal{N}$; but since it adds one transposition to the associated permutation of each path system, it negates each term in the sum over $\mathcal{S} \setminus \mathcal{N}$. Therefore, it negates the entire sum over $\mathcal{S} \setminus \mathcal{N}$. Therefore we must have that the given sum over all $\mathcal{P} \in \mathcal{S} \setminus \mathcal{N}$ is equal to its negative, and hence the sum over $\mathcal{S} \setminus \mathcal{N}$ is 0, as desired. Therefore, we have

$$\det M = \sum_{\mathcal{P} \in \mathcal{N}} \text{sign}(\sigma(\mathcal{P})) \omega(\mathcal{P}).$$

2.2.2 Shifted Plane Partitions

Definition 2.5 (Plane Partition). *A plane partition π of shape λ is a labelling of each square in the diagram of λ with positive integers (formally, a map $Y(\lambda) \rightarrow \mathbb{Z}^+$) such that each square's label is at least as large as the labels below and to the right of it.*

Definition 2.6 (Shifted Plane Partition). *A shifted plane partition σ of shape λ is a labelling of each square in the shifted diagram of λ with positive integers (formally, a map $S(\lambda) \rightarrow \mathbb{Z}^+$) such that each square's label is at least as large as the labels below and to the right of it.*

Definition 2.7 (Definitions Related to (Shifted) Plane Partitions). *Suppose that λ is a partition with plane partition π and shifted plane partition σ . Then,*

1. Both π or σ are called *row-strict* if each square's label is strictly greater than the label of the square to the right of it. Similarly, they are called *column-strict* if each square's label is strictly greater than the label of the square below it.
2. σ is called *diagonal-strict* if each square's label is strictly greater than the label of the square to the bottom-right of it. The notion of *diagonal-strict* is not used for normal plane partitions.
3. The profile of π are all the entries down the left column, and the profile of σ are all the entries down the left diagonal.
4. The k th shape $\text{sh}_k(\pi)$ is the partition μ defined by $\mu_i = \max\{j \mid \pi(i, j) \geq k\}$. For example, $\text{sh}_1(\pi) = \lambda$. Similarly, we define the k th shape $\text{sh}_k(\sigma)$ to be the partition μ defined by $\mu_i = \max\{j \mid \pi(i, j) \geq k\} - i + 1$, so that again $\text{sh}_1(\sigma) = \lambda$.

I like to imagine plane partitions geometrically; assigning a positive integer to each square can be envisioned as placing some number of unit cubes on each square. This helps me understand profiles and shapes: the profile of a plane partition is what the plane partition looks like from the left, and the k th shape is the k th plane of the 3D shape (that is, all the cubes stacked on top of $(k - 1)$ cubes).

Definition 2.8 (Partially Strict Shifted Plane Partitions). *Let A and B be complementary subsets of \mathbb{Z}^+ . An (A, B) -partially strict shifted plane partition σ is a shifted plane partition satisfying*

1. for any $m \in A$, m appears at most once in each row.
2. for any $m \in B$, m appears at most one in each column.

For example, if A is the set of even positive integers, and B is the set of odd positive integers, then

$$\begin{array}{cccccc} 8 & 6 & 5 & 5 & 5 & 2 & 1 \\ & 6 & 4 & 3 & 3 & 2 & \\ & & 4 & 2 & 1 & 1 & \\ & & & & 1 & & \end{array}$$

is an (A, B) -partially strict shifted plane partition of shape $(7, 5, 4, 1)$ and $(8, 6, 4, 1)$. □

2.2.3 Lattice Paths and Generating Functions

Definition 2.9 (Weights). *Let z_1, \dots, z_n be indeterminants. For a (shifted) plane partition $\pi = (a_{ij})$, the weight z^π of π is the monomial $z^\pi = \prod_{i,j} z_{a_{ij}}$. We define the generating function $F(X; z)$ for a set of (shifted) plane partitions to be the formal expression*

$$F(X; z) = \sum_{\pi \in X} z^\pi$$

For example, the weight of the above example is $z_8 z_6^2 z_5^3 z_4^2 z_3^2 z_2^3 z_1^4$.

Definition 2.10 (Distinct Partition). *A distinct partition λ is a partition where all the parts $\lambda_1, \dots, \lambda_n$ are distinct; that is, a distinct partition satisfies*

$$\lambda_1 > \lambda_2 > \dots > \lambda_n.$$

Definition 2.11. *Let $\lambda = (\lambda_1, \dots, \lambda_r)$ and $a = (a_1, \dots, a_r)$ be two distinct partitions with length r . Then $\mathcal{S}_{A,B}(\lambda; a)$ is the set of all (A, B) -partially strict shifted plane partitions with the shape λ and the profile a .*

Definition 2.12. *Let $\tilde{q}_k^{(m)}(z) = \tilde{q}_{A,B,k}^{(m)}(z)$ be the polynomial in z_1, \dots, z_m defined by*

$$\sum_{k=0}^{\infty} \tilde{q}_k^{(m)}(z) t^k = \prod_{i \in A \cap [m]} (1 + z_i t) \cdot \prod_{j \in B \cap [m]} (1 - z_j t)^{-1}.$$

The first main result from Okada is the following:

Theorem 2.1 (Okada 1). *For distinct partitions λ and a of the same length r ,*

$$F(\mathcal{S}_{A,B}(\lambda; a); z) = \det(\tilde{q}_{\lambda_i}^{(a_j)}(z) - \tilde{q}_{\lambda_i}^{(a_j-1)}(z))_{1 \leq i, j \leq r}.$$

To prove this result, we need to develop some more theory.

2.2.4 Lattice Paths and Connections to Plane Partitions

Definition 2.13 ((A, B) -Acyclic Plane). *Suppose that A and B are complementary subsets of \mathbb{Z}^+ . Then, the (A, B) -acyclic plane is the directed graph whose vertices are the elements of \mathbb{N}^2 and edges are given as so:*

Let $(i, j) \in \mathbb{N}^2$. Then define the following directed edges starting at (i, j) :

$$\begin{cases} (i, j) \rightarrow (i+1, j-1) & \text{if } i = 0 \text{ and } j \in A \\ (i, j) \rightarrow (i+1, j) & \text{if } i = 0 \text{ and } j \in B \\ (i, j) \rightarrow (i+1, j-1) \text{ and } (i, j) \rightarrow (i, j-1) & \text{if } i > 0 \text{ and } j \in A \\ (i, j) \rightarrow (i+1, j) \text{ and } (i, j) \rightarrow (i, j-1) & \text{if } i > 0 \text{ and } j \in B \\ \text{No edges} & \text{if } j = 0. \end{cases}$$

Each edge on this graph is weighted as so:

1. *If the edge travels from (i, j) to $(i+1, j')$, then the edge is given the weight z_i .*
2. *If the edge travels from (i, j) to (i, j') , then the edge is given the weight 1.*

We will consider paths on the (A, B) -acyclic plane.

Definition 2.14. *For two distinct partitions λ and a of the same length r , let $\mathcal{L}^0(\lambda; a)$ be the set of all non-intersecting path systems with source vertices $(0, a_r), \dots, (0, a_1)$ and sink vertices $(\lambda_r, 0), \dots, (\lambda_1, 0)$. Let $l(\lambda; a)$ denote the sum of the weights $w(P)$ of all of the path systems in $\mathcal{L}^0(\lambda; a)$ (as defined in Lem 2.0.5).*

Lemma 2.1.1. *There is a weight-preserving one-to-one correspondence from $\mathcal{S}_{A,B}(\lambda; a)$ to $\mathcal{L}^0(\lambda; a)$. Hence,*

$$F(\mathcal{S}_{A,B}(\lambda; a); z) = l(\lambda; a).$$

Proof. Take a shifted plane partition $\sigma = (a_{ij})$ in $\mathcal{S}_{A,B}(\lambda; a)$ —that is, σ is (A, B) -partially strict and has shape λ and profile a . Now, both λ and a have some length, say r . We associate to σ the path system $\mathcal{P}(\sigma) = (p_1, \dots, p_r)$, where p_i is a path from $(0, a_i)$ to $(\lambda_i, 0)$ defined by:

For each $j = i, \dots, \lambda_i + i - 1$, we append the edge starting at $(j-i, a_{ij})$ and ending at the following point

$$\begin{cases} (j-i+1, a_{ij}-1) & \text{if } a_{ij} \in A \\ (j-i+1, a_{ij}) & \text{if } a_{ij} \in B. \end{cases}$$

Then, we append the necessary vertical edges to complete the path.

This description is not very intuitive, so we additionally offer the following description of the construction:

1. For each row μ of the shifted plane partition, we create a path.
2. Begin at $(\mu_0, 0)$. Then, draw a directed edge right if $\mu_0 \in A$ or down-and-to-the-right if $\mu_0 \in B$.
3. Now, begin at $(\mu_1, 1)$. Then, draw a directed edge right if $\mu_0 \in A$ or down-and-to-the-right if $\mu_0 \in B$.
4. Repeat until you run out of parts of the partition μ .

5. Notice that there might be some gaps: if $\mu_i \in A$ but $\mu_i > \mu_{i+1}$, then the path will move horizontally from (μ_i, i) to $(\mu_i, i + 1)$, and the next segment of the path will begin too low. Similarly, if $\mu_i \in B$ but $\mu_i - 1 > \mu_{i+1}$, then the path will not move down enough to “catch up” to the next segment of the path. When these issues arise, add vertical line segments to correct for the gaps.
6. Finally, our path will not end low enough whenever the final part of μ is larger than 1 or A does not contain 1. Therefore, we again append vertical line segments to fix this issue.

The result is a non-intersecting path system on the (A, B) -acyclic plane. Seeing why it is non-intersecting also sheds light on why this correspondence is from (A, B) -partially strict plane partitions, instead of any possible plane partition. Explicitly, the partial strictness of the partition is necessary to get a valid *non-intersecting* path. In fact, all of the requirements are necessary (and indeed sufficient):

1. The partitions λ and a need to be distinct to avoid two paths ending at the same vertex.
2. The points need to be weakly decreasing from left to right so that they are following valid edges in the (A, B) -acyclic plane. Similarly, the points need to be weakly decreasing from top to bottom to avoid crossing over.
3. The partition needs to be (A, B) -partially strict in order to avoid a collision (the requirement for B) or a jagged edge which involves heading upwards (the requirement for A). In more detail, it's fine to have two elements from B in a single row, because we only travel horizontally at that point – but two elements from A would force us to head right-down, pop up a vertex, and then head right-down again. Similar arguments help us dissect the condition for B .

□

For example, if $A = \{2, 4, 6, \dots\}$ and $B = \{1, 3, 5, \dots\}$, we associate to the shifted plane partition

$$\sigma = \begin{array}{cccccc} & 5 & 4 & 3 & 3 & 2 \\ & & 4 & 2 & 1 & \\ & & & 2 & & \end{array}$$

the following 3-path $\Lambda(\sigma)$ (diagram by Chavdar):

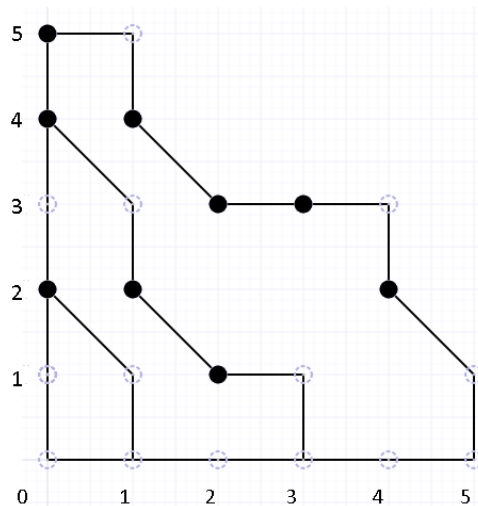

Lemma 2.1.2. $l(\lambda; a) = \det(l(\lambda_i; a_j))_{1 \leq i, j \leq r}$.

Proof. This is a simple application of the Lindstrom-Gessel-Viennot Lemma on the (A, B) -acyclic plane, since the only non-intersecting path systems are all necessarily associated with the identity permutation. □

Lemma 2.1.3. For any integer k , $\sum_{l=1}^m l(k; l) = \tilde{q}_k^{(m)}(z)$.

Proof. By the definition of $\tilde{q}_k^{(m)}(z)$, we see that

$$\tilde{q}_k^{(m)}(z) = \sum_{\alpha} z_1^{\alpha_1} z_2^{\alpha_2} \cdots z_m^{\alpha_m},$$

where α run over all $\alpha = (\alpha_1, \dots, \alpha_m) \in \mathbb{Z}_{\geq 0}^m$ such that $\alpha_1 + \cdots + \alpha_m = k$ and α_i is 0 or 1 for $i \in A$. Each term $z_1^{\alpha_1} \cdots z_m^{\alpha_m}$ in the above sequence corresponds to the lattice path which goes from $(0, l)$ to $(k, 0)$ ($l = \max\{j \mid \alpha_j \neq 0\}$) and which consists of the edges

$$\begin{aligned} (k - \alpha_1 - \cdots - a_i, i) &\rightarrow (k - \alpha_1 - \cdots - a_{i-1}, i) \text{ for all } i \in A \\ (k - \alpha_1 - \cdots - a_i, i) &\rightarrow (k - \alpha_1 - \cdots - a_{i-1}, i - 1) \text{ for all } i \in B \end{aligned}$$

as well as the necessary vertical edges. This correspondence proves this lemma. \square

Together these lemmas prove the desired result, which also has the following corollary:

Corollary 2.1.1. *Let $\mathcal{R}(\lambda; a)$ (resp. $\mathcal{C}(\lambda; a)$) be the set of row-strict (resp. column-strict) shifted plane partitions with the shape λ and the profile a . Since $\mathcal{R}(\lambda; a) = \mathcal{S}_{\mathbb{Z}^+, \emptyset}(\lambda; a)$ and $\mathcal{C}(\lambda; a) = \mathcal{S}_{\emptyset, \mathbb{Z}^+}(\lambda; a)$,*

$$\begin{aligned} F(\mathcal{R}(\lambda; a); x) &= \det \left(e_{\lambda_i}^{(a_j)}(x) - e_{\lambda_i}^{(a_j-1)}(x) \right)_{1 \leq i, j \leq r}, \\ F(\mathcal{C}(\lambda; a); x) &= \det \left(h_{\lambda_i}^{(a_j)}(x) - h_{\lambda_i}^{(a_j-1)}(x) \right)_{1 \leq i, j \leq r}, \end{aligned}$$

Proof. Put $A = \mathbb{Z}^+$ and $B = \emptyset$ or $A = \emptyset$ and $B = \mathbb{Z}^+$. \square

2.2.5 A Proof of Tokuyama's Formula by Plane Partitions

Definition 2.15. *Let E (resp. O) be the set of even (resp. odd) positive integers. Define*

$$\tilde{\mathcal{D}}(\lambda; a) = \bigcup_b \mathcal{S}_{E, O}(\lambda; b),$$

where b ranges over all distinct partitions $b = (b_1, \dots, b_r)$ of length r such that $b_i = 2a_i$ or $2a_i - 1$. For $\sigma \in \tilde{D}(\lambda; a)$, we denote by $P(\sigma)$ the shifted plane partition obtained by replacing $2i - 1$ and $2i$ by i for $i = 1, 2, \dots$. Note that $P(\sigma) \in \mathcal{D}(\lambda; a)$.

Proposition 2.1.1. *If $\sigma \in \mathcal{D}(\lambda; a)$,*

$$\sum_{\substack{\tau \in \tilde{D}(\lambda; a) \\ P(\tau) = \sigma}} t^{e(\tau)} = \left(1 + \frac{1}{t} \right)^{h(\sigma)} t^{f(\sigma)}$$

where $e(\tau)$ denotes the number of even entries in τ . In particular, by setting $t = 1$, the number of $\tau \in \tilde{D}(\lambda; a)$ such that $P(\tau) = \sigma$ is equal to $2^{h(\sigma)}$.

Proof. For $\sigma \in \mathcal{D}(\lambda; a)$, we can construct all shifted plane partitions $\tau \in \tilde{D}(\lambda; a)$ such that $P(\tau) = \sigma$ as so:

Let $c_1^{(k)}, \dots, c_{h_k}^{(k)}$ be the connected components of the diagram $S(\text{sh}_k(\sigma) - \text{sh}_{k+1}(\sigma))$. Then for any given rim hook c_j^k , $\tau_{c_j^k}$ is completely determined except for the entry at the bottom left and is either

$$\begin{array}{cccccc} & & & 2k & & 2k-1 & \cdots & & & & 2k & & 2k-1 & \cdots \\ & & & \vdots & & & & & & & \vdots & & & \\ 2k & & & & & & & & & & 2k & & & & 2k-1 \\ & & & \vdots & & & & & & & \vdots & & & \\ & & & 2k & & & & & & & 2k & & & \\ 2k-1 & & & & & & & & & & & & & & 2k \end{array}$$

Hence

$$\sum_{\tau} t^{e(\tau)} = \prod_{j,k} \left(t^{r(c_i^{(k)})} + t^{r(c_j^{(k)})-1} \right) = \left(1 + \frac{1}{t} \right)^{h(\sigma)} t^{f(\sigma)}.$$

□

Theorem 2.2.

$$\sum_{\sigma \in \tilde{D}(\lambda; a)} \left(1 - \frac{1}{t} \right)^{h(\sigma)} (-t)^{f(\sigma)} x^{\sigma} = \det(q_{\lambda_i}^{(a_j)}(x; t) - q_{\lambda_i}^{(a_j-1)}(x; t))_{1 \leq i, j \leq r},$$

where $q_k^{(m)}(x; t)$ is the polynomial in x_1, \dots, x_m and t defined by using the generating function

$$\sum_{k=0}^{\infty} q_k^{(m)}(x; t) y^k = \prod_{i=1}^m \frac{1 - tx_i y}{1 - x_i y}.$$

Proof. Denote the left-hand side of (2) by $G(\lambda; a)$. Then Proposition 2.1.1 says that

$$G(\lambda; a) = F(\tilde{D}(\lambda; a); z)[z_{2i-1} \rightarrow x_i][z_{2i} \rightarrow -tx_i]$$

where for a polynomial $f(z)$ in z_1, z_2, \dots , the notation $f(z)[z_j \rightarrow x_k]$ indicates that we substitute x_k for z_j in $f(z)$. Then, from Theorem 2.1 and the definition of $\tilde{D}(\lambda; a)$, we see that if $r = l(\lambda) = l(a)$,

$$\begin{aligned} F(\tilde{D}(\lambda; a); z) &= \sum_{\varepsilon \in \{0, -1\}^r} \det(\tilde{q}_{E, O, \lambda_j}^{2a_i + \varepsilon_i}(z) - \tilde{q}_{E, O, \lambda_j}^{2a_i + \varepsilon_i - 1}(z)) \\ &= \det(\tilde{q}_{E, O, \lambda_j}^{2a_i}(z) - \tilde{q}_{E, O, \lambda_j}^{2a_i - 2}(z)) \end{aligned}$$

Yet one may reasonably notice that

$$\tilde{q}_{E, O, k}^{(2m)}(z)[z_{2i-1} \rightarrow x_i][z_{2i} \rightarrow -tx_i] = q_k^{(m)}(x; t).$$

Hence the result $G(\lambda; a) = \det(q_{\lambda_j}^{(a_i)}(x; t) - q_{\lambda_j}^{(a_i-1)}(x; t))$ follows. □

Let $\rho = (r, r-1, \dots, 2, 1)$ and λ be a distinct partition. We define a bijection $\Psi : \mathcal{D}(\lambda; \rho) \rightarrow \text{SGT}(\lambda)$ by letting the k th row of $\Psi(\sigma)$ be $\text{sh}_k(\sigma)$ for $\sigma \in \mathcal{D}(\lambda; \rho)$. For example,

$$\Psi \begin{pmatrix} 3 & 3 & 2 & 1 \\ & 2 & 2 & 1 \\ & & 1 & \end{pmatrix} = \begin{pmatrix} 4 & 3 & 1 \\ 3 & 2 \\ 2 \end{pmatrix}$$

Proposition 2.2.1. For $\sigma \in \mathcal{D}(\lambda; \rho)$ with length r , the bijection Ψ satisfies:

$$g(\Psi(\sigma)) = h(\sigma) - r \quad l(\Psi(\sigma)) = f(\sigma) - h(\sigma).$$

Proof. Let $\sigma = (a_{ij}) \in \mathcal{D}(\lambda; \rho)$ and $\Psi(\sigma) = (t_{ij}) \in \mathcal{M}(\lambda)$. Then it follows from the definition of Ψ that t_{ij} is generic (resp. left-leaning) if and only if $a_{j, l-1} > a_{jl} > a_{j+1, l}$ (resp. $a_{j, l-1} > a_{jl} = a_{j+1, l}$), where $l = t_{i, j} + j$. Hence we have

$$\begin{aligned} g(\Psi(\sigma)) &= |\{(i, j) \mid i < j \text{ and } a_{i, j-1} > a_{ij} > a_{i+1, j}\}| \\ &= h(\sigma) - r \\ l(\Psi(\sigma)) &= |\{(i, j) \mid a_{ij} = a_{i+1, j}\}| = f(\sigma) - h(\sigma). \end{aligned}$$

□

Now we are prepared for the final proof.

Theorem 2.3 (Tokuyama). *Let λ be a partition of length at most n , and $\rho = (n-1, n-2, \dots, 1, 0)$. Then,*

$$\sum_{T \in \text{SGT}(\lambda+\rho)} (t+1)^{g(T)} t^{l(T)} \prod_{i=1}^n z_i^{d_i(T)} = \prod_{i < j} (z_i + tz_j) s_\lambda(z_1, \dots, z_n)$$

where $s_\lambda(z_1, \dots, z_n)$ is a Schur polynomial.

Proof. Let $M(\lambda)$ denote the left-hand side of the above polynomial. It follows from Proposition 2.2.1 that

$$M(\lambda) = \sum_{\sigma \in \mathcal{D}(\lambda+\rho; \rho)} (t+1)^{h(\sigma)-n} t^{f(\sigma)-h(\sigma)} x^\sigma = (t+1)^{-n} \sum_{\sigma \in \mathcal{D}(\lambda+\rho; \rho)} \left(1 + \frac{1}{t}\right)^{h(\sigma)} t^{f(\sigma)} x^\sigma.$$

Now, define $X_{ij} = (1+t)^{-1} (q_i^{(j)}(x; -t) - q_i^{(j-1)}(x; -t))$. By Theorem 2.2, we have

$$M(\lambda) = \det(X_{(\lambda_i+\rho_i), n-j+1})_{1 \leq i, j \leq n},$$

Next, for $I = \{i_1, \dots, i_m\}$, define $x_I = x_{i_1} x_{i_2} \cdots x_{i_m}$. Similarly, let $h_k(I)$ be the k th complete symmetric polynomial in x_{i_1}, \dots, x_{i_m} . Note that $h_k(I) = 0$ if $k < 0$. From the definition of $q_k^{(m)}(x; t)$, we see that $q_k^{(m)}(x; -t) = \sum_{\alpha} (1+t)^{n(\alpha)} x_1^{\alpha_1} \cdots x_m^{\alpha_m}$, where α runs over all $\alpha = (\alpha_1, \dots, \alpha_m) \in \mathbb{Z}_{\geq 0}^m$ such that $\alpha_1 + \cdots + \alpha_m = k$ and $n(\alpha)$ is the number of non-zero α_i .

Therefore, we have $q_k^{(m)}(x; -t) = \sum_{I \subseteq [m]} (1+t)^{|I|} x_I h_{k-|I|}(I)$, so that

$$X_{ij} = \sum_{I \subseteq [j-1]} (1+t)^{|I|} x_I x_j h_{i-|I|-1}(I \cup \{j\}).$$

Now, for $i \geq 1$ and $j > k \geq 1$, we put

$$X_{ij}^{(k)} = \sum_{I \subseteq [j-k-1]} (1+t)^{|I|} x_I h_{i-|I|-k}(I \cup \{j-k, j-k-1, \dots, j\}).$$

For all $l \geq 1$, we also have that

$$tx^l + (1+t) \sum_{k=1}^{l-1} x^k y^{l-k} + y^l = (tx+y) \sum_{k=0}^{l-1} x^k y^{l-k-1}.$$

We also have that $\sum_{k=0}^l h_k(I) h_{l-k}(J) = h_l(I \cup J)$ if $I \cap J = \emptyset$. Together, these two facts imply that

$$\begin{aligned} X_{ij} + tX_{i,j-1} &= (tx_{j-1} + x_j) X_{ij}^{(1)} & (j \geq 2) \\ X_{ij}^{(k-1)} - X_{i,j-1}^{(k-1)} &= (tx_{j-k} + x_j) X_{ij}^{(k)} & (j > k \geq 2) \end{aligned}$$

by direct computation.

For convenience, we define $X_{ij}^{(k)} = X_{ij}^{(j-1)}$ for $j \leq k$. Then, we see that

$$X_{\lambda_i+\rho_i, r-j+1} = \prod_{l=1}^{r-1} (tx_l + x_{l+1}) \cdot \det(X_{\lambda_i+\rho_i, r-j+1}^{(l)})$$

from the first of the two above equations, and if $2 \leq k \leq r-1$, by the second equation we have

$$\det(X_{\lambda_i+\rho_i, r-j+1}^{(k-1)}) = \prod_{l=1}^{r-k} (tx_l + x_{l+k}) \cdot \det(X_{\lambda_i+\rho_i, r-j+1}^{(k)}).$$

Hence we obtain

$$M(\lambda) = \prod_{k < l} (tx_k + x_l) \cdot \det(X_{\lambda_i + \rho_i, r-j+1}^{(r-1)}).$$

On the other hand, $X_{\lambda_i + \rho_i, r-j+1}^{(r-1)} = X_{\lambda_i + \rho_i, r-j+1}^{(r-j)} = h_{\lambda_i + j - r}([r - j + 1])$. Then the result follows from [Wac85], which states that

$$\det(h_{\mu_i - i + j}([r - j + 1]))_{1 \leq i, j \leq r} = s_{\mu}(x_1, \dots, x_r)$$

for a partition μ of length $\leq r$. This implies the desired result

$$M(\lambda) = \prod_{i \leq j} (tx_i + x_j) \cdot s_{\lambda}(x_1, \dots, x_r).$$

□

2.3 Lattice Models Proof by Brubaker, Bump, Friedberg

We will present another proof of Tokuyama's formula using the Gamma Ice model, which is a lattice model coming from Statistical Mechanics. The presentation here is adapted from [BBF10]. We will omit most of the details. And we will focus on the definition of the Gamma Ice model and the main tool used to prove Tokuyama's formula called the Yang-Baxter equation.

First, we need to define what the Gamma Ice model is. Given a partition λ , we create a grid of vertices with $\lambda_1 + 1$ as the width and $\ell(\lambda)$ as the height. Each vertex has four attached circles, as in figure 6.

An alternative way to think about this model is that it is a graph where the vertices are joined by an edge to their neighbor vertices, and we allow outgoing edges for the boundary vertices. So then each vertex has four outgoing edges. We then put a circle on each edge.

Regardless of how we think of the vertices, we will fill the circles with either a plus or minus. We first fill the boundary and then the interior. For the boundary, we put minus signs in the circles in the right column. Given λ we also put minus signs in the circles above the vertices that have a number that appears in λ . Otherwise, we put plus signs in the boundary. The figure 6 shows this for $\lambda = (5, 2, 0)$

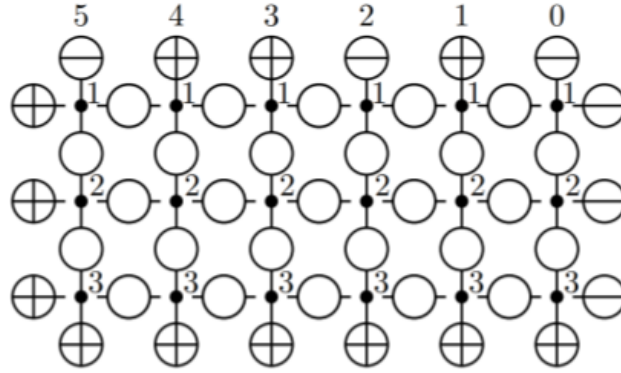

Figure 6: Partially filled Gamma Ice model

We now fill the interior of the grid. There are multiple ways of filling it. What we do is to pick a bijection between the minus signs in the top row and the minus sign in the right column. We then draw a path from a circle in the top row to its associated circle in the right column. The path has to go through the vertices. We impose the restriction that no two paths can go through the same edge. We also forbid paths that go up or to the left. Given these paths, we put minus signs in the circles that the paths go through. Otherwise, we put plus signs. The figure 7 on the next page shows the grid for a particular choice of paths.

For a fixed λ , let us call a Gamma Ice configuration to a choice of the paths described above. It is easy to see the following

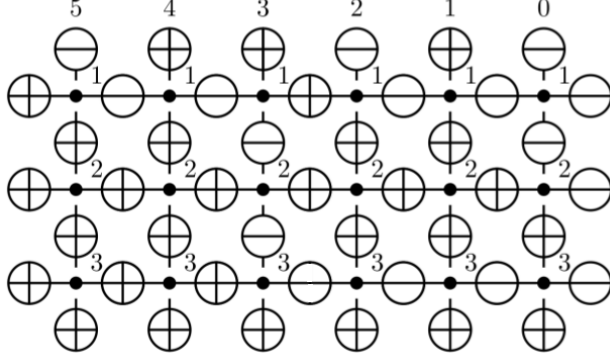

Figure 7: Fully filled Gamma Ice model

Proposition 2.3.1. *Fix a partition λ . Gamma Ice configurations for λ are in bijection with strict Gelfand-Tsetlin patterns with top row λ .*

In the same way that the summand on the left-hand side of Tokuyama's formula is a weight for a SGT pattern, we can define a weight for a Gamma Ice configuration. We will not describe the details here. It suffices to say that we can do it in such a way that the following equation holds.

$$\sum_{T \in \text{SGT}(\lambda + \rho_n)} (t+1)^{g(T)} t^{l(T)} \prod_{i=1}^n z_i^{d_i(T)} = \sum_{C \in \text{GI}(\lambda + \rho_n)} w(C) \quad (18)$$

where $\text{GI}(\lambda)$ is the set of Gamma Ice configurations with top row λ and $w(C)$ is the weight associated to the Gamma Ice configuration C .

Thus, to prove Tokuyama's formula 1.1, it suffices to prove that the right-hand side of 18 equals the right-hand side of Tokuyama's formula.

To do this, we define

$$r_\lambda = \frac{\sum_{C \in \text{GI}(\lambda + \rho_n)} w(C)}{\prod_{i < j} (t_i z_j + z_i)}. \quad (19)$$

Now, by looking at the right-hand side of Tokuyama's expression, we see that it suffices to show that r_λ is equal to the Schur Polynomial.

The main tool is the following

Lemma 2.3.1. *The expression $(t_i z_k + z_{k+1}) \sum_{C \in \text{GI}(\lambda + \rho_n)} w(C)$ is invariant under the interchange $(z_k, t_k) \longleftrightarrow (z_{k+1}, t_{k+1})$.*

Proof. The proof is an application of the Yang-Baxter equation, which we will now describe. The Yang-Baxter equation states that, if we introduce a new vertex with a certain weight, then we can move that vertex throughout the columns without changing the value of $\sum_{C \in \text{GI}(\lambda + \rho_n)} w(C)$. The figure 8 on the following page shows this equality.

By applying the Yang-Baxter equation many times we get an equality of the sum of the weights corresponding to a standard Gamma Ice model with a vertex adjoined at the left (figure 9 on the next page) to the sum of the weights corresponding to a standard Gamma Ice model with a vertex adjoined at the right (figure 11 on page 22.) By the choice of weights of the adjoined vertices (which we did not detail here), the equality between the left and right Gamma Ice models corresponds to the invariance under the interchange $(z_k, t_k) \longleftrightarrow (z_{k+1}, t_{k+1})$ and so we are done. \square

Given this lemma, it is easy to see that r_λ is the Schur polynomial. Indeed, the lemma shows that $\sum_{C \in \text{GI}(\lambda + \rho_n)} w(C)$ is divisible by $\prod_{i < j} (t_i z_j + z_i)$ and hence r_λ is a polynomial in z_i independent of t . From here, a straightforward computation shows that r_λ equals the Schur polynomial.

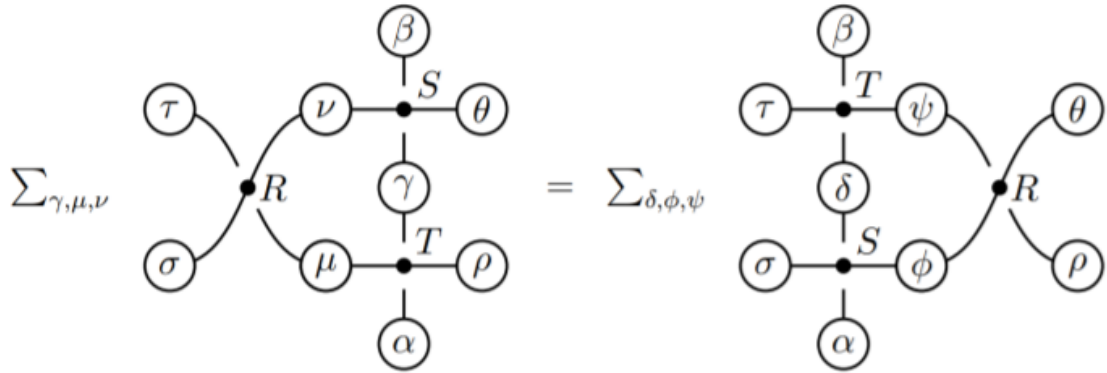

for every fixed combination of spins $\sigma, \tau, \alpha, \beta, \rho, \theta$.

Figure 8: Yang-Baxter equation

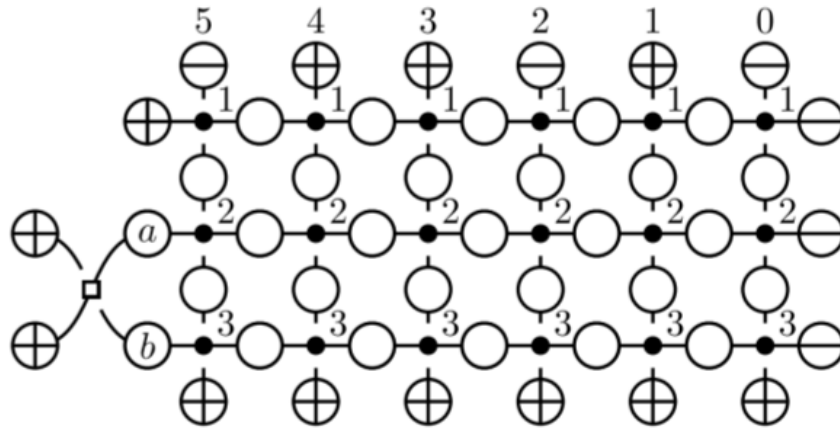

Figure 9: Gamma Ice configuration with adjoined vertex on the left

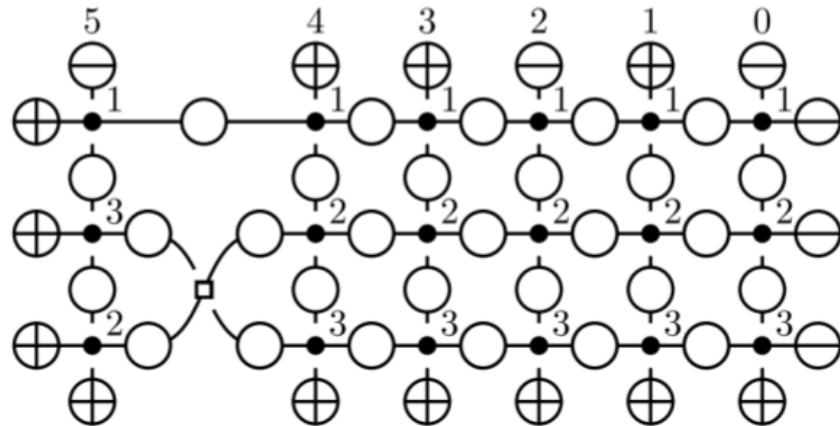

Figure 10: Gamma Ice configuration with adjoined vertex on the interior

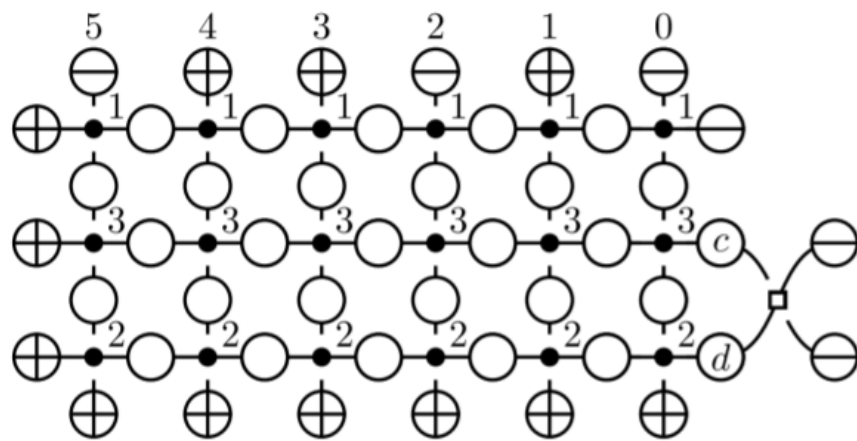

Figure 11: Gamma Ice configuration with adjoined vertex on the right

3 New Proofs

Our long-term goal is eventually to generalize Tokuyama's formula to analogous results over other reductive groups. However, with this goal in mind, each of these previously discussed proofs has a major downside. Namely,

1. The direct proof uses Pieri's formula and branching rules, which are either unwieldy or simply do not exist for other reductive groups.
2. Okada's proof makes use of a complex determinant identity for Schur polynomials which has its own paper and to which an analogue for other reductive groups would be difficult to appeal.
3. The lattice model proof is the most promising (indeed, solvable lattice models have already proven one analogous Tokuyama's formula for symplectic groups, as we discuss later), but still the construction feels ad-hoc and unmotivated.

This gives us motivation to find new proofs of Tokuyama's formula which avoid these downsides. We have found two such proofs, which is what we will now present.

3.1 New Direct Proof

In this section, we present a new direct proof for Tokuyama's formula. The proof is inspired by Dan Bump's direct approach, but avoids using Pieri's formula and branching rules for the Schur polynomials. By doing so, we hope that it is more easily generalizable to other groups.

Proof of Tokuyama's Formula (2). Define L and R as in (8), which we restate here for convenience:

$$L(\lambda; t; z_1, \dots, z_n) := \sum_{T \in \text{SGT}(\lambda + \rho_n)} \left((t+1)^{g(T)} t^{l(T)} \prod_{i=1}^n z_i^{d_i(T)} \right)$$

$$R(\lambda; t; z_1, \dots, z_n) := \left(\prod_{1 \leq i < j \leq n} (z_i + tz_j) \right) s_\lambda(z_1, \dots, z_n).$$

We construct a chain of equalities that shows directly that $L = R$, after application of the inductive hypothesis. We begin with the recursion relation for L , which is obtained by simply factoring out the "contribution" of possible second rows to the weights of the Gelfand-Tsetlin patterns T . More precisely, let M_1 be the set of partitions ν such that $\nu + \rho_{n-1}$ interleaves $\lambda + \rho_n$. Then

$$L(\lambda; t; z_1, z_2, \dots, z_n) = \sum_{\nu \in M_1} t^{l(\lambda, \nu)} (1+t)^{g(\lambda, \nu)} z_1^{m_1(\lambda, \nu)} L(\nu; t; z_2, \dots, z_n).$$

Applying the inductive hypothesis lets us change the L in the sum to a R , so we have

$$= \sum_{\nu \in M_1} t^{l(\lambda, \nu)} (1+t)^{g(\lambda, \nu)} z_1^{m_1(\lambda, \nu)} R(\nu; t; z_2, \dots, z_n). \quad (20)$$

Now, substituting the definition of R into (20) and rearranging, we obtain

$$\sum_{\nu \in M_1} \left(t^{l(\lambda, \nu)} (1+t)^{g(\lambda, \nu)} z_1^{m_1(\lambda, \nu)} \prod_{1 < i < j \leq n} (z_i + tz_j) s_\nu(z_2, \dots, z_n) \right)$$

$$= \prod_{1 < i < j \leq n} (z_i + tz_j) \sum_{\nu \in M_1} t^{l(\lambda, \nu)} (1+t)^{g(\lambda, \nu)} z_1^{m_1(\lambda, \nu)} s_\nu(z_2, \dots, z_n). \quad (21)$$

Recall now that the Schur polynomial s_ν can be given as a ratio of determinants using Jacobi's bi-alternant formula (1):

$$s_\nu(z_2, \dots, z_n) = \frac{a_{\nu + \rho_{n-1}(z_2, \dots, z_n)}}{a_{\rho_{n-1}(z_2, \dots, z_n)}}, \quad (22)$$

where the a_ν are given in 1.5. Substituting (22) into (21) and expanding the antisymmetric polynomial $a_{\nu+\rho_{n-1}}$, we obtain

$$\begin{aligned}
& \prod_{1 < i < j \leq n} (z_i + tz_j) \sum_{\nu \in M_1} t^{l(\lambda, \nu)} (1+t)^{g(\lambda, \nu)} z_1^{m_1(\lambda, \nu)} \frac{a_{\nu+\rho_{n-1}}(z_2, \dots, z_n)}{a_{\rho_{n-1}}(z_2, \dots, z_n)} \\
&= \frac{\prod_{1 < i < j \leq n} (z_i + tz_j)}{a_{\rho_{n-1}}} \sum_{\nu \in M_1} \left(t^{l(\lambda, \nu)} (1+t)^{g(\lambda, \nu)} z_1^{m_1(\lambda, \nu)} \sum_{\sigma \in S_{n-1}} \operatorname{sgn}(\sigma) z^{\sigma(\nu+\rho_{n-1})} \right) \\
&= \frac{\prod_{1 < i < j \leq n} (z_i + tz_j)}{a_{\rho_{n-1}}} \sum_{\sigma \in S_{n-1}} \operatorname{sgn}(\sigma) \sum_{\nu \in M_1} t^{l(\lambda, \nu)} (1+t)^{g(\lambda, \nu)} z_1^{m_1(\lambda, \nu)} z^{\sigma(\nu+\rho_{n-1})}. \tag{23}
\end{aligned}$$

We will use the term **partial GT pattern** to mean a truncated GT pattern having only two rows. In this context in particular, we will use the term to refer to partial GT patterns whose first row is $\lambda + \rho_n$. Similarly, for a given $\sigma \in S_{n-1}$ and a given partial GT pattern T , we will use the term **partial weight of T with respect to σ** to mean the term

$$\operatorname{sgn}(\sigma) t^{l(\lambda, \nu)} (1+t)^{g(\lambda, \nu)} z_1^{m_1(\lambda, \nu)} z^{\sigma(\nu+\rho_{n-1})}.$$

We will generally omit reference to σ and call these terms simply the partial weights.

We now would like to factor $\prod_{j=2}^n (z_1 + tz_j)$ out from the sum of partial weights in (23). However, this is not clearly possible in general, since we may end up with an odd number of monomial terms in the inner sum when we expand the partial weights, but to factor out a binomial $(z_1 + tz_j)$, we would need an even number of monomial terms. The trick is to expand our domain of summation without changing the overall value. In particular, let M_2 be the set of $(n-1)$ -tuples ν such that $\nu + \rho_{n-1}$ interleaves $\lambda + \rho_n$. Notice that this domain includes non-partitions, which correspond to second rows $\nu + \rho_{n-1}$ that are non-strict. For instance, the GT pattern corresponding to $\lambda = (4, 2, 2)$ has top row $\lambda + \rho_3 = (6, 3, 2)$. If we relax the restriction that the second row has to be strict, then a possible second row is $\nu + \rho_2 = (3, 3)$, and so the tuple $\nu = (2, 3)$ belongs to M_2 (but not to M_1).

We will expand the inner sum to let ν range over M_2 instead of M_1 . For now, we will take it as fact that this domain expansion will not affect the value of (23) and will revisit the matter later. With this in mind, we now write (23) as

$$\frac{\prod_{1 < i < j \leq n} (z_i + tz_j)}{a_{\rho_{n-1}}} \sum_{\sigma \in S_{n-1}} \operatorname{sgn}(\sigma) \sum_{\nu \in M_2} t^{l(\lambda, \nu)} (1+t)^{g(\lambda, \nu)} z_1^{m_1(\lambda, \nu)} z^{\sigma(\nu+\rho_{n-1})}. \tag{24}$$

In order to establish now that each factor $(z_1 + tz_j)$ for $j \in \{2, \dots, n\}$ divides the sum of partial weights in (24), we fix $\sigma \in S_{n-1}$ and list the partial GT patterns determined by the first row $\lambda + \rho_n$ and second row $\nu + \rho_{n-1}$ as ν ranges over M_2 . We note the corresponding weights of the patterns, expanding any $(1+t)^{g(\lambda, \nu)}$ factors so we are left with monomials. For each j , we then form a pairing of partial GT patterns that satisfies two main properties. The first property is that for each pair (T_1, T_2) of partial GT patterns, the partial weight for T_1 contains a monomial of the form Cz_1 for some expression C , and the weight for T_2 contains a monomial of the form Ctz_j for the same expression C . Thus, the sum of these monomials is $Cz_1 + Ctz_j = C(z_1 + tz_j)$, and so the factor $(z_1 + tz_j)$ may be obtained from the sum of these two monomials. The second property is that each monomial appearing in the weight of a partial GT pattern is paired once and only once with a monomial appearing in the weight of another partial GT pattern. If these two conditions are satisfied, then the sum of all of the partial weights of the partial GT patterns must be divisible by $(z_1 + tz_j)$, since each pair sum is divisible by $(z_1 + tz_j)$. We do this pairing for each j .

Such a pairing is first illustrated by means of an example. We see in figure 12 on the next page and figure 13 on the following page the pairing for the partial patterns that have top row $\lambda + \rho_n = (6, 3, 1)$ in the case that σ is the identity.

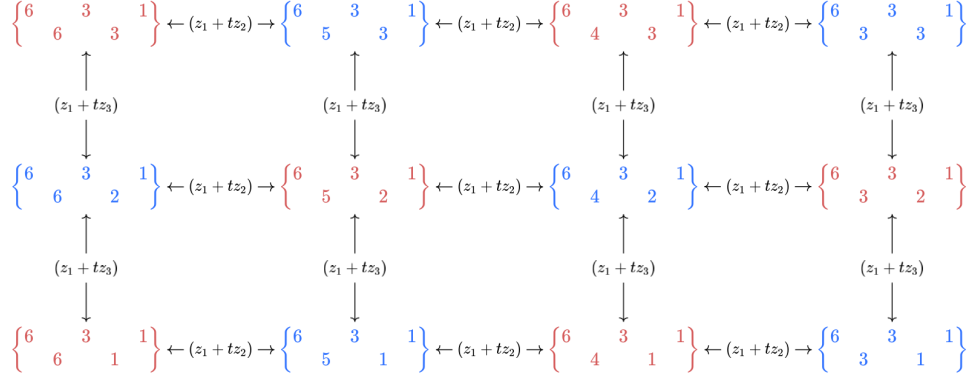

Figure 12: Example pairing for partial Gelfand-Tsetlin patterns having top row $\lambda + \rho_n = (6, 3, 1)$, depicted on the level of patterns.

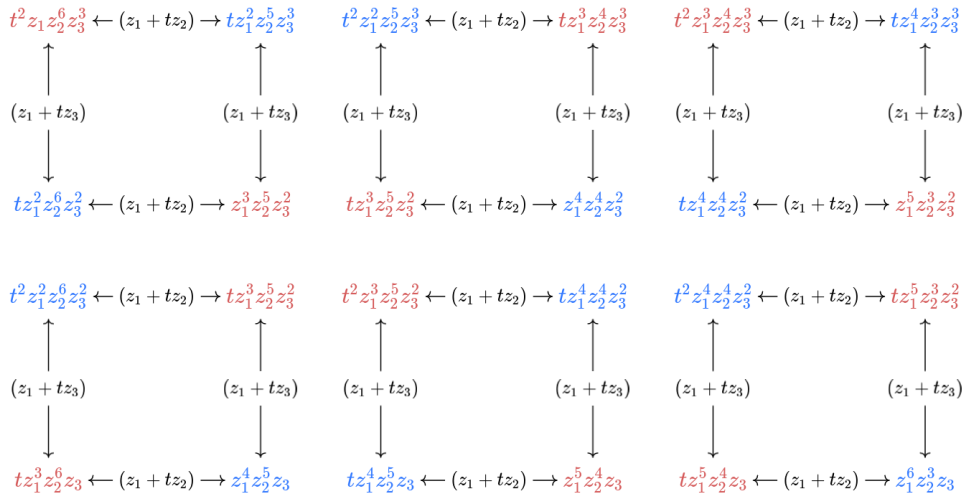

Figure 13: Example pairing for partial Gelfand-Tsetlin patterns having top row $\lambda + \rho_n = (6, 3, 1)$, depicted on the level of monomials.

More generally, for a fixed σ and a fixed j , we will pair partial Gelfand-Tsetlin patterns T_1 and T_2 if and only if the $\sigma^{-1}(j-1)$ -st entry of T_1 is exactly 1 less than the $\sigma^{-1}(j-1)$ -st entry of T_2 . It is not hard to see that such a pairing is correct: the $(z_1 + tz_j)$ pairings for each j may be made independently of each other, and since only the $\sigma^{-1}(j-1)$ -st entry affects the exponent of z_j in the corresponding monomials, we may imagine fixing all entries except the $\sigma^{-1}(j-1)$ -st entry and pairing these.

For illustration purposes, let $\alpha = (\lambda + \rho_n)_{\sigma^{-1}(j-1)}$ and $\beta = (\lambda + \rho_n)_{\sigma^{-1}(j-1)+1}$, and vary the $\sigma^{-1}(j-1)$ -st entry in the second row through all possible values while keeping everything else constant. Then the fixed entries outside these three entries contribute some common factor C to the monomial terms corresponding to the partial Gelfand-Tsetlin patterns as we vary $\sigma^{-1}(j-1)$ -st entry in the second row, and we need only keep track of changes in the exponent on t , z_1 , and z_j . At the far left end of figure 14 on the next page, the $\sigma^{-1}(j-1)$ -st entry in the second row is left-leaning and so has value α . The contribution of the three entries shown to the corresponding monomial term is a factor of $tz_1^\beta z_j^\alpha$. We pair this partial pattern with the partial pattern obtained by decrementing the $\sigma^{-1}(j-1)$ -st entry in the second row by 1, giving us $\alpha - 1$ there. In general, this is a generic entry, and so the partial pattern will have two monomials summed together: one with a factor of $tz_1^{\beta+1} z_j^{\alpha-1}$, and one with a factor of $z_1^{\beta+1} z_j^{\alpha-1}$. We see

that $Ctz_1^\beta z_j^\alpha + Cz_1^{\beta+1} z_j^{\alpha-1} = (z_1 + tz_j)Ctz_1^\beta z_j^{\alpha-1}$, so we obtain a factor of $(z_1 + tz_j)$ from this pair. We continue making these pairings, until the $\sigma^{-1}(j-1)$ -st entry in the second row is right-leaning, having value β . At each step, we get a monomial pairing whose sum contains a factor $(z_1 + tz_j)$. We can repeat this chain argument for each $\sigma \in S_{n-1}$, each index j , and each choice of entries fixed outside of the the $\sigma^{-1}(j-1)$ -st entry in the second row to get a factor of $\prod_{j=2}^n (z_1 + tz_j)$ from the sum (24).

$$\begin{array}{ccccccc} \left\{ \begin{array}{ccc} \cdots \alpha & \beta \cdots & \\ \cdots & \alpha & \cdots \end{array} \right\} & \longleftrightarrow & \left\{ \begin{array}{ccc} \cdots \alpha & & \beta \cdots \\ \cdots & \alpha-1 & \cdots \end{array} \right\} & \longleftrightarrow & \cdots & \longleftrightarrow & \left\{ \begin{array}{ccc} \cdots \alpha & & \beta \cdots \\ \cdots & \beta+1 & \cdots \end{array} \right\} & \longleftrightarrow & \left\{ \begin{array}{ccc} \cdots \alpha & & \beta \cdots \\ \cdots & \beta & \cdots \end{array} \right\} \\ \\ Ctz_1^\beta z_j^\alpha & \longleftrightarrow & Cz_1^{\beta+1} z_j^{\alpha-1} + Ctz_1^{\beta+1} z_j^{\alpha-1} & \longleftrightarrow & \cdots & \longleftrightarrow & Cz_1^{\alpha-1} z_j^{\beta+1} + Ctz_1^{\alpha-1} z_j^{\beta+1} & \longleftrightarrow & Cz_1^\alpha z_j^\beta \end{array}$$

Figure 14: A “chain” argument which pairs partial Gelfand-Tsetlin patterns to extract the factor $(z_1 + tz_j)$ for a given j and $\sigma \in S_{n-1}$.

With this divisibility statement shown, we may rewrite (24) as

$$\begin{aligned} & \frac{\prod_{1 \leq i < j \leq n} (z_i + tz_j)}{a_{\rho_{n-1}}} \sum_{\sigma \in S_{n-1}} \operatorname{sgn}(\sigma) \prod_{j=2}^n (z_1 + tz_j) \left(\frac{\sum_{\nu \in M_2} t^{l(\lambda, \nu)} (1+t)^{g(\lambda, \nu)} z_1^{m_1(\lambda, \nu)} z^{\sigma(\nu + \rho_{n-1})}}{\prod_{j=2}^n (z_1 + tz_j)} \right) \\ &= \frac{\prod_{1 \leq i < j \leq n} (z_i + tz_j)}{a_{\rho_{n-1}}} \left(\frac{\sum_{\sigma \in S_{n-1}} \operatorname{sgn}(\sigma) \sum_{\nu \in M_2} t^{l(\lambda, \nu)} (1+t)^{g(\lambda, \nu)} z_1^{m_1(\lambda, \nu)} z^{\sigma(\nu + \rho_{n-1})}}{\prod_{j=2}^n (z_1 + tz_j)} \right), \end{aligned}$$

wherein the bracketed factor is a polynomial (since we precisely showed that the product $\prod_{j=2}^n (z_1 + tz_j)$ divides the sum). We can now change the numerator of the bracketed sum back into the equivalent form in which the inner sum has domain M_1 , since as we will see shortly, the sum has the same value when taken over either M_1 or M_2 :

$$\frac{\prod_{1 \leq i < j \leq n} (z_i + tz_j)}{a_{\rho_{n-1}}} \left(\frac{\sum_{\sigma \in S_{n-1}} \operatorname{sgn}(\sigma) \sum_{\nu \in M_1} t^{l(\lambda, \nu)} (1+t)^{g(\lambda, \nu)} z_1^{m_1(\lambda, \nu)} z^{\sigma(\nu + \rho_{n-1})}}{\prod_{j=2}^n (z_1 + tz_j)} \right). \quad (25)$$

Since the bracketed factor is a polynomial and the numerator and denominator have the same degree in t , it must be independent of t . Thus, we will set $t = -1$ inside the bracketed factor. This value of t gives us the factors $\prod_{j=2}^n (z_1 - z_j)$ in the denominator, which can be combined with the $a_{\rho_{n-1}}$ in the denominator of the coefficient outside the brackets to obtain a_{ρ_n} .

Moreover, setting $t = -1$ lets us eliminate all ν in the numerator which give a GT-pattern containing generic terms. We are thus left with only those ν containing no generic terms, i.e., the ν containing left- and right-leaning terms only. Since the sum is over M_1 , corresponding to strict Gelfand-Tsetlin patterns, we have only $n-1$ possible choices for ν , since there cannot be any right-leaning terms in the second row whose neighbor to the right is a left-leaning term. Namely, these are the partitions which give k left-leaning entries, for $k = 0$ to $k = n-1$. Hence, we write (25) as

$$\begin{aligned} & \frac{\prod_{1 \leq i < j \leq n} (z_i + tz_j)}{a_{\rho_{n-1}}} \left(\frac{\sum_{\sigma \in S_{n-1}} \operatorname{sgn}(\sigma) \sum_{k=0}^{n-1} (-1)^{k-1} z_1^{\lambda_k + n - k} z^{\sigma(\lambda_1 + n - 1, \dots, \lambda_{k-1} + n - k + 1, \lambda_{k+1} + n - k - 1, \dots, \lambda_n)}}{\prod_{j=2}^n (z_1 - z_j)} \right) \\ &= \frac{\prod_{1 \leq i < j \leq n} (z_i + tz_j)}{a_{\rho_n}} \sum_{\sigma \in S_{n-1}} \operatorname{sgn}(\sigma) \sum_{k=0}^{n-1} (-1)^{k-1} z_1^{\lambda_k + n - k} z^{\sigma(\lambda_1 + n - 1, \dots, \lambda_{k-1} + n - k + 1, \lambda_{k+1} + n - k - 1, \dots, \lambda_n)}. \end{aligned}$$

We now swap the order of summation and recognize that the sum is exactly the Laplace expansion of $a_{\lambda + \rho_n}$,

expanding down the first column. Hence, we get

$$\begin{aligned}
& \frac{\prod_{1 \leq i < j \leq n} (z_i + tz_j)}{a_{\rho_n}} \sum_{k=0}^{n-1} (-1)^{k-1} z_1^{\lambda_k + n - k} \sum_{\sigma \in S_{n-1}} \text{sgn}(\sigma) z^{\sigma(\lambda_1 + n - 1, \dots, \lambda_{k-1} + n - k + 1, \lambda_{k+1} + n - k - 1, \dots, \lambda_n)} \\
&= \frac{\prod_{1 \leq i < j \leq n} (z_i + tz_j)}{a_{\rho_n}(z_1, z_2, \dots, z_n)} a_{\lambda + \rho_n}(z_1, z_2, \dots, z_n) \\
&= \prod_{1 \leq i < j \leq n} (z_i + tz_j) s_{\lambda}(z_1, z_2, \dots, z_n) \\
&= R(\lambda; t; z_1, z_2, \dots, z_n),
\end{aligned}$$

as desired.

We return to the final matter of verifying that the domain expansion in (24) does not change the value of (23). The reason for this invariance is due to cancellation that occurs in the outer sum in (23) over S_{n-1} . Suppose $\nu \in M_2 - M_1$, so that $\nu + \rho_{n-1}$ gives a non-strict second row. Assume that there is only one value which is repeated in $\nu + \rho_{n-1}$, as the method easily generalizes to the case that there are multiple values which appear more than once in $\nu + \rho_{n-1}$.

For $k > 1$, let $I = \{i_1, i_2, \dots, i_k\}$ be the indices of $\nu + \rho_{n-1}$ which contain the repeated value, i.e.,

$$\nu_{i_1} + (n-1) - i_1 = \nu_{i_2} + (n-1) - i_2 = \dots = \nu_{i_k} + (n-1) - i_k.$$

Consider now the stabilizer $\text{Stab}(\nu + \rho_{n-1})$ of $\nu + \rho_{n-1}$ under the action of S_{n-1} . Since we have assumed that the entries of $\nu + \rho_{n-1}$ which are not indexed by I are distinct, and since any permutation of the entries indexed by I stabilizes $\nu + \rho_{n-1}$, we see that $\text{Stab}(\nu + \rho_{n-1})$ is isomorphic to S_k .

Because $k > 1$, exactly half of the permutations in $\text{Stab}(\nu + \rho_{n-1})$ are even (having positive sign) and exactly half of the permutations are odd (having negative sign). Since $\sigma_1(\nu + \rho_{n-1}) = \sigma_2(\nu + \rho_{n-1})$ for any $\sigma_1, \sigma_2 \in \text{Stab}(\nu + \rho_{n-1})$, we see that the terms corresponding to $\sigma \in \text{Stab}(\nu + \rho_{n-1})$ in the sum (24) exactly cancel. Similar cancellation occurs in each coset of $\text{Stab}(\nu + \rho_{n-1})$. Thus, (23) and (24) have the same value. \square

3.2 New Combinatorial Proof of Tokuyama's formula

In this section we provide our new elementary combinatorial proof of Tokuyama's formula.

3.2.1 Primed Strict GT-patterns

First, we introduce the notion of a primed strict GT-pattern. A ‘‘primed entry’’ is simply a normal entry of a GT-pattern which has been annotated with a tick mark – examples are below.

Definition 3.1. *A **primed strict Gelfand-Tsetlin (PSGT) pattern** is a strict GT pattern for which we*

- *prime all left-leaning entries;*
- *do not prime any right-leaning entries;*
- *choose whether to prime each generic entry.*

Denote the set of primed strict GT patterns with top row λ with $\text{PSGT}(\lambda)$.

Remark 3.1. *Each strict GT pattern T gives rise to $2^{g(T)}$ primed strict GT patterns where $g(T)$ is the number of generic terms of T .*

Definition 3.2. *For each primed strict GT pattern T with n rows we define the **weight***

$$w(T) = t^{\# \text{ primed entries}} \prod_{i=1}^n z_i^{d_i}$$

where d_i is defined as in Definition 1.9.

Example 3.1.1. *The set $\text{PSGT}((2, 0))$ has four patterns:*

$$\begin{array}{cccc} 2 & 0 & 2 & 0 \\ 2' & & 1' & \\ & & & 1 \\ & & & 0 \end{array} \quad \begin{array}{cccc} 2 & 0 & 2 & 0 \\ & & & \\ & & & \\ & & & \end{array} \quad \begin{array}{cccc} 2 & 0 & 2 & 0 \\ & & & \\ & & & \\ & & & \end{array} \quad \begin{array}{cccc} 2 & 0 & 2 & 0 \\ & & & \\ & & & \\ & & & \end{array}$$

$$tz_2^2 \quad tz_1z_2 \quad z_1z_2 \quad z_1^2$$

We now reframe Tokuyama's formula in terms of primed strict GT patterns.

Proposition 3.0.1 (Combinatorial Tokuyama formula).

$$\sum_{T \in \text{PSGT}(\lambda + \rho_n)} t^{\# \text{ primed}} \prod_{i=1}^n z_i^{d_i(T)} = \sum_{T \in \text{SGT}(\lambda + \rho_n)} t^{l(T)} (1+t)^{g(T)}$$

Proof. Let $T_0 \in \text{SGT}(\lambda + \rho)$. Denote by $\text{PSGT}(T_0)$ the set of primed strict GT patterns that can be created by priming the entries of T_0 . Then

$$\begin{aligned} w(T_0) &= t^{l(T_0)} (1+t)^{g(T_0)} \prod_{i=1}^n z_i^{d_i(T_0)} \\ &= \sum_{i=0}^{g(T_0)} \binom{g(T_0)}{i} t^{l(T_0)+i} \prod_{i=1}^n z_i^{d_i(T)} \\ &= \sum_{T \in \text{PSGT}(T_0)} w(T) \end{aligned} \tag{26}$$

where the second equality holds because there are $\binom{g(T_0)}{i}$ ways to prime exactly i generic entries of T_0 . \square

Corollary 3.0.1. *Tokuyama's formula is equivalent to proving*

$$\sum_{T \in \text{PSGT}(\lambda + \rho_n)} t^{\# \text{ primed}} \prod_{i=1}^n z_i^{d_i(T)} = \prod_{i=1}^n z_i^{d_i(T)} \cdot \prod_{i < j} (z_i + tz_j) s_\lambda(z_1, \dots, z_n)$$

Example 3.1.2 (Combinatorial Tokuyama). *For $\lambda = (1, 0)$, we have $\lambda + \rho_2 = (2, 0)$. The set $\text{PSGT}((2, 0))$ is:*

$$\begin{array}{cccc} 2 & 0 & 2 & 0 \\ 2' & & 1' & \\ & & & 1 \\ & & & 0 \end{array} \quad \begin{array}{cccc} 2 & 0 & 2 & 0 \\ & & & \\ & & & \\ & & & \end{array} \quad \begin{array}{cccc} 2 & 0 & 2 & 0 \\ & & & \\ & & & \\ & & & \end{array} \quad \begin{array}{cccc} 2 & 0 & 2 & 0 \\ & & & \\ & & & \\ & & & \end{array}$$

and the sum of the respective weights is:

$$tz_2^2 + tz_1z_2 + z_1 + z_2 + z_1^2 = (z_1 + tz_2)(z_1 + z_2)$$

The advantage of working with the combinatorial Tokuyama formula is that the factors $(z_i + tz_j)$ have a simple combinatorial interpretation. The factor $(z_i + tz_j)$ tells us that we can pair all primed strict GT patterns with a fixed top row so that the weight of each pair is divisible by $(z_i + tz_j)$.

3.2.2 A Proof by a Pairing Algorithm

We now use primed strict GT patterns to prove Tokuyama's formula.

Proposition 3.0.2. *The factor $z_1 + tz_2$ is a divisor of*

$$\sum_{T \in \text{PSGT}(\lambda + \rho_n)} t^{\# \text{ primed}} \prod_{i=1}^n z_i^{d_i(T)}$$

$e = c - 1$. Then we cannot do the substitution $c' \rightarrow c - 1$ as then $e = c - 1$ will have to be primed. These are the frozen states from Definition 3.4.

If $e = c - 1'$ then $d < c - 1$. So the substitution $c' \rightarrow c - 1$ is valid. If $e < c - 1$, then because $e \geq d$ we can again perform the substitution $c' \rightarrow c - 1$.

Thus, the value (including if it is primed) of e uniquely determines if the pairing algorithm can change c' . On the other hand, the value of d is not important.

Second case: Our entry is not primed; denote it by c . We would like to substitute c with $c + 1'$.

$$\begin{array}{rcl} \text{1st row} & & b \\ \text{2nd row} & d & c \\ \text{3rd row} & & e \end{array}$$

This case is completely analogous to the first case. Again only the frozen states from Definition 3.4 can prevent the substitution $c \rightarrow c + 1'$ and the value of the entry to the bottom left of c gives necessary and sufficient conditions for the substitution to be valid. \square

It is remarkable that the entries on the third determine if the pairing algorithm can change a particular entry. From the proof of Lemma 3.0.1 we get the following Corollary:

Corollary 3.0.2. *The third row of a primed strict GT pattern uniquely determines if a particular entry on the second row is in a frozen state.*

We are now ready to prove f is well defined.

Lemma 3.0.2 (Well-defined). *For all $T \in \text{PSGT}(\lambda + \rho_n)$, there is always at least one element on the second row of T which is not in a frozen state.*

Proof. Assume for the sake of contradiction that there is a T such that each entry on the second row is part of a frozen state.

Hence, the first entry from left to right must be primed and the last entry cannot be primed. Now notice that at some point in the triangle there will be a frozen state of a primed entry followed by frozen state of a non-primed entry. There are two possible configurations :

$$\begin{array}{rclclcl} \text{1st row} & & a & & a & \\ \text{2nd row} & c' & & c - 1 & & c' & & c - 1 \\ \text{3rd row} & & c' & & & c - 1 & & \end{array}$$

However, both of these configurations are illegal because no matter what value of a we choose the primes on the second row will create an invalid pattern. We have reached a contradiction which completes the proof. \square

Next we show f groups all $T \in \text{PSGT}(\lambda + \rho_n)$ into pairs.

Lemma 3.0.3 (Involution). *We have*

$$f^2(T) = T$$

Proof. Let $T \in \text{PSGT}(\lambda + \rho_n)$. We have to show $f(f(T)) = T$.

Let c be the first entry on the second row of T which is not in a frozen state. Then $f(T)$ changed the value of exactly that entry. Denote the new entry by c_0 . When computing $f(f(T))$, notice that c_0 is not in a frozen state. This is because if we increased c by one and primed it, we can decrease c_0 and unprime it and vice versa. Moreover, by Corollary 3.0.2 there cannot be an element that is not frozen in the second row of $f(T)$ which precedes c_0 . \square

Hence our proof of Proposition 3.0.2 is complete. \square

Corollary 3.0.3. *The factor $z_1 + tz_2$ divides*

$$\sum_{T \in \text{SGT}(\lambda + \rho_n)} t^{l(T)} (1+t)^{g(T)} \prod_{i=1}^n z_i^{d_i(T)}$$

Proof. The corollary follows directly from Proposition 3.0.1 and Proposition 3.0.2. \square

Proof of Theorem 1.1. Now Theorem 1.1 follows easily from Corollary 3.0.3. Indeed,

$$L(\lambda, t, z_1, \dots, z_n) = \prod_{1 < i < j \leq n} (z_i + tz_j) \sum_{\mu} t^{l(\lambda, \mu)} (1+t)^{g(\lambda, \mu)} z_1^{m(\lambda, \mu)} s_{\mu}(z_2, \dots, z_n)$$

However, because Schur polynomials are symmetric, if $(z_1 + tz_2)$ divides the sum over partitions μ , all of the factors $(z_1 + tz_i)$ also divide it. Hence, $\prod_{1 \leq i < j \leq n} (z_i + tz_j)$ divides $L(\lambda, t, z_1, \dots, z_n)$. We notice the exponent of t is the same on both sides of Tokuyama's expression and thus set $t = -1$. Now it is easy to prove Tokuyama's formula in a similar manner to the Direct Proof in Subsection 3.1. \square

4 Symplectic Tokuyama's Formula

Recall from the introduction that the purpose of Tokuyama's formula is to give a combinatorial evaluation of the spherical Whittaker function on $\text{GL}(n)$. However, there are other types of reductive groups besides general linear groups, and so we are interested in finding similar combinatorial evaluations of the spherical Whittaker function in those cases. We consider here the equivalent of Tokuyama's formula over the symplectic groups $\text{Sp}(2n)$.

4.1 The Statement of the Symplectic Tokuyama's Formula

In the case of Tokuyama's formula (2), the combinatorial objects of concern were strict GT patterns. A similar sort of combinatorial object exists for $\text{Sp}(2n)$, whose description appears in, e.g., [Pro94]. We will call these objects "symplectic GT patterns," which we define now.

Definition 4.1 (Symplectic Gelfand-Tsetlin Pattern). *A **symplectic Gelfand-Tsetlin** (GT^{Sp}) pattern is a skew-triangular array of non-negative integers*

$$\begin{bmatrix} a_{1,1} & & & & & & & a_{1,n} \\ & a_{2,1} & & & & & & a_{2,n} \\ & & a_{3,2} & & & & & a_{3,n} \\ & & & a_{4,2} & & & & a_{4,n} \\ & & & & \ddots & & & \vdots \\ & & & & & a_{2n-1,n} & & \vdots \\ & & & & & & & a_{2n,n} \end{bmatrix}$$

satisfying $a_{2i-1,j} \geq a_{2i,j} \geq a_{2i-1,j+1}$ and $a_{2i,j} \geq a_{2i+1,j+1} \geq a_{2i,j+1}$ (called the **in-betweenness condition**) and $a_{2i-1,j} \geq 1$. The set of symplectic Gelfand-Tsetlin patterns having top row λ is denoted $\text{GT}^{\text{Sp}}(\lambda)$.

As in the $\text{GL}(n)$ case, the combinatorial object which appears in Tokuyama's formula for the $\text{Sp}(2n)$ case has the additional constraint of having strictly decreasing rows. We thus define the strict GT^{Sp} patterns as follows.

Definition 4.2 (Strict Symplectic Gelfand-Tsetlin Pattern). *A **strict Symplectic Gelfand-Tsetlin** (SGT^{Sp}) pattern is a symplectic Gelfand-Tsetlin pattern such that $a_{i,j} > a_{i,j+1}$ for each i, j . The set of all strict symplectic Gelfand-Tsetlin patterns having top row λ is denoted $\text{SGT}^{\text{Sp}}(\lambda)$.*

It is again convenient for us to associate an SGT^{Sp} to any partition λ , not just strictly decreasing partitions. We thus define a distinguished partition $\rho_n^{\text{Sp}} = (n, n-1, \dots, 2, 1)$, and we find that any given SGT^{Sp} belongs to some set $\text{SGT}^{\text{Sp}}(\lambda + \rho_n^{\text{Sp}})$ for some λ .

Example 4.0.1 (Example GT^{Sp} Pattern and SGT^{Sp} Pattern). Let $\lambda = (2, 1, 1)$. Then we might have the following example GT^{Sp} patterns:

$$\begin{bmatrix} 2 & & & & \\ & 1 & & & \\ & & 1 & & \\ & & & 1 & \\ & & & & 1 \end{bmatrix} \in \text{GT}^{\text{Sp}}(\lambda), \quad \text{and} \quad \begin{bmatrix} 5 & & & & \\ & 3 & & & \\ & & 2 & & \\ & & & 2 & \\ & & & & 3 \\ & & & & & 2 \\ & & & & & & 1 \end{bmatrix} \in \text{SGT}^{\text{Sp}}(\lambda + \rho_3^{\text{Sp}}).$$

Similar to the standard GT patterns from the $\text{GL}(n)$ case, we will categorize entries in an GT^{Sp} depending on their relationships to the entries immediately above them.

Definition 4.3 (Leaning Entries). Given an GT^{Sp} pattern T , we say an entry $a_{2i-1,j}$ below the top row is

- (a) **left-leaning** if $a_{2i-1,j} = a_{2i-2,j-1}$, that is, if the entry is equal to the entry above and to the left;
- (b) **right-leaning** if $a_{2i-1,j} = a_{2i-2,j}$, that is, if the entry is equal to the entry above and to the right; and
- (c) **generic** otherwise.

Similarly, we say an entry $a_{2i,j}$ below the top row is

- (a) **left-leaning** if $a_{2i,j} = a_{2i-1,j}$, that is, if the entry is equal to the entry above and to the left;
- (b) **right-leaning** if $a_{2i,j} = a_{2i-1,j+1}$ or $a_{2i,j} = 0$, that is, if the entry is equal to the entry above and to the right or is 0; and
- (c) **generic** otherwise.

As before, we shall define notation for the combinatorial data of an GT^{Sp} pattern T . Unlike the combinatorial data of GT patterns, however, we care about counting the number of left-leaning entries in only odd rows of T , and we care about right-leaning terms in even rows of T .

Notation 4.3.1 (Combinatorial Data of GT^{Sp} Patterns). Let T be an GT^{Sp} pattern. Then we use the following notation:

- (a) The number of left-leaning entries in odd rows of T is denoted $l_o(T)$.
- (b) The number of right-leaning entries in even rows of T is denoted $r_e(T)$.
- (c) The number of generic entries in T is denoted $g(T)$.
- (d) The sum of the entries in the i -th row is denoted $s_i(T)$.
- (e) The value $s_{2i-1}(T) - 2s_{2i}(T) + s_{2i+1}(T)$ is denoted $d_i(T)$.

If T has n rows, then we define $d_n(T)$ to have the value $s_{2n-1}(T) - 2s_{2n}(T)$.

Now that the right combinatorial objects have been characterized, we can present a statement of the symplectic Tokuyama's formula. Like the $\text{GL}(n)$ case, we will have on one side a sum over the weights of some combinatorial object (namely, SGT^{Sp} patterns), and on the other side we will have a deformed Weyl denominator multiplied by an irreducible character of $\text{Sp}(2n)$, denoted by $\chi_\lambda^{\text{Sp}}(z)$.

Theorem 4.1 (Symplectic Tokuyama's Formula). Let λ be a partition of length $\ell(\lambda) \leq n$, and $\rho_n^{\text{Sp}} = (n, n-1, \dots, 2, 1)$. Then,

$$\sum_{T \in \text{SGT}^{\text{Sp}}(\lambda + \rho_n^{\text{Sp}})} t^{r_e(T) + l_o(T)} (1+t)^{g(T)} \prod_{i=1}^n z_i^{d_i(T)} = z^{-\rho_n^{\text{Sp}}} \prod_{i=1}^n (1 + tz_i^2) \prod_{i < j} (1 + tz_i z_j)(1 + tz_i z_j^{-1}) \chi_\lambda^{\text{Sp}}(z) \quad (27)$$

where $\chi_\lambda^{\text{Sp}}(z_1, \dots, z_n)$ is an irreducible character of $\text{Sp}(2n)$.

Remark 4.1 (Weyl’s Character Formula). *In the $\mathrm{GL}(n)$ case, the irreducible characters were the Schur polynomials s_λ , for which we had an explicit description via antisymmetric polynomials and Jacobi’s bi-alternant formula. For the $\mathrm{Sp}(2n)$ case, we have something similar that uses tools from the representation theory of Lie groups. Namely, we can compute the characters χ_n^{Sp} using **Weyl’s character formula**, which for $\mathrm{Sp}(2n)$ is given by*

$$\chi_n^{\mathrm{Sp}}(z_1, \dots, z_n) = \frac{\sum_{w \in W} (-1)^{\ell(w)} z^{w(\lambda + \rho_n^{\mathrm{Sp}})}}{\prod_{\alpha \in \Phi^+} (z^{\alpha/2} - z^{-\alpha/2})} = \frac{\sum_{w \in W} (-1)^{\ell(w)} z^{w(\lambda + \rho_n^{\mathrm{Sp}})}}{z^{-\rho_n^{\mathrm{Sp}}} \prod_{i=1}^n (1 - z_i^2) \prod_{i < j} (1 - z_i z_j)(1 - z_i z_j^{-1})},$$

where $W = (\mathbb{Z}/2\mathbb{Z})^n \rtimes S_n$ is the Weyl group of $\mathrm{Sp}(2n)$, $\ell(\cdot)$ is the length function on W , and Φ^+ is the positive root system of $\mathrm{Sp}(2n)$.

We now describe the approach used by Ivanov to prove this theorem before discussing the progress we have made in adapting our proof of Tokuyama’s formula to the symplectic case.

4.2 Review of Existing Methods

The only known proof of the Symplectic Tokuyama’s formula was written by Ivanov and appears in Chapter 10 of the book *Multiple Dirichlet Series, L-functions and Automorphic Forms* [Iva12]. The proof is similar to the one we outlined in Section 2.3 for the general linear group. However, the fact that the character and Casselman-Shalika expression for the symplectic group are more involved translates to having a more involved proof.

Ivanov extended the Gamma Ice model described in Section 2.3 to a model that has two types of vertices. To show the equivalent of Lemma 2.3.1 in this context, we use the Yang-Baxter equation. However, this invariance requires us to apply the Yang-Baxter equation in multiple rows at the same time, as depicted in figure 15 on the following page. In this context, the Yang-Baxter equation will not be enough to prove the invariance that we need. Thus, Ivanov introduces a new operation where we allow to attach a cap (a vertex on the right of the grid), as in figure 16 on the next page. Applying many times the Yang-Baxter equation leads us to figure 17 on the following page. Finally, Ivanov proves that the loop (or “fish”) attached on the right can be simplified to a cap. This equality in the Ice models is then translated to an statement about invariance of the equivalent term to r_λ for this context.

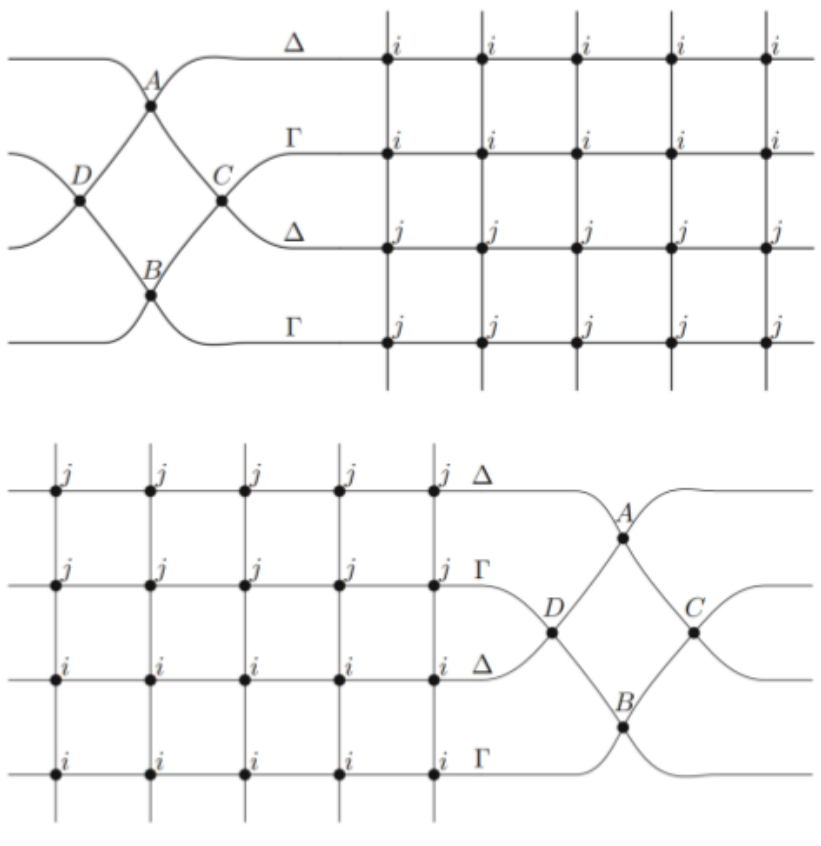

Figure 15: Yang-Baxter equation

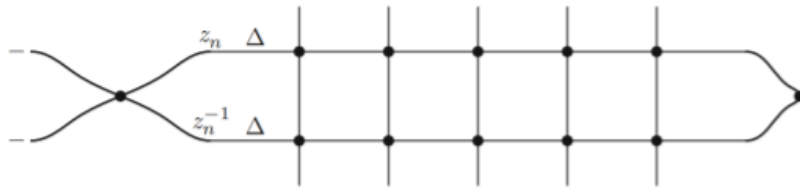

Figure 16: Grid with vertices attached on the left and the right

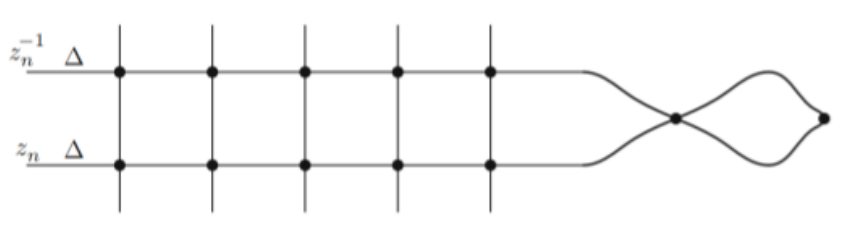

Figure 17: Grid from figure 16 after applying the Yang-Baxter equation

4.3 The Direct Method for the Symplectic Tokuyama Formula

We now proceed to describe the progress we have made in adapting our direct method to the symplectic case. While the proof is not yet completed, the approach seems promising and the gaps feel quite tractable.

Let λ be a partition of length $\leq n$ and consider the set $\text{SGT}^{\text{Sp}}(\lambda + \rho_n^{\text{Sp}})$ of strict symplectic GT-patterns having top row $\lambda + \rho_n^{\text{Sp}}$, where $\rho_n^{\text{Sp}} = (n, n-1, \dots, 2, 1)$. Then, as given in (27), the symplectic Tokuyama formula states

$$\sum_{T \in \text{SGT}^{\text{Sp}}(\lambda + \rho_n^{\text{Sp}})} t^{r_e(T) + l_o(T)} (1+t)^{g(T)} \prod_{i=1}^n z_i^{d_i(T)} = z^{-\rho_n^{\text{Sp}}} \prod_{i=1}^n (1 + tz_i^2) \prod_{i < j} (1 + tz_i z_j) (1 + tz_i z_j^{-1}) \chi_{\lambda}^{\text{Sp}}(z).$$

Now define L and R to be the left and right sides of (27), respectively:

$$\begin{aligned} L(\lambda; t; z_1, \dots, z_n) &= \sum_{T \in \text{SGT}^{\text{Sp}}(\lambda + \rho_n^{\text{Sp}})} t^{r_e(T) + l_o(T)} (1+t)^{g(T)} \prod_{i=1}^n z_i^{d_i(T)} \\ R(\lambda; t; z_1, \dots, z_n) &= z^{-\rho_n^{\text{Sp}}} \prod_{i=1}^n (1 + tz_i^2) \prod_{i < j} (1 + tz_i z_j) (1 + tz_i z_j^{-1}) \chi_{\lambda}^{\text{Sp}}(z). \end{aligned} \tag{28}$$

If we are to proceed by induction on n in a manner analogous to the $\text{GL}(n)$ case, we must sum over the possible choices for the next *two* rows. Define $\rho_n = (n-1, \dots, 1, 0)$ and define the sets

$$\begin{aligned} M &:= \{\text{partitions } \nu \text{ such that } \nu + \rho_n \text{ interleaves } \lambda + \rho_n^{\text{Sp}}\} \\ N_{\nu} &:= \{\text{partitions } \theta \text{ such that } \theta + \rho_{n-1}^{\text{Sp}} \text{ interleaves } \nu + \rho_n\}, \text{ for } \nu \in M. \end{aligned}$$

In other words, M is the set of partitions ν such that $\nu + \rho_n$ is a second row in at least one $T \in \text{SGT}^{\text{Sp}}(\lambda + \rho_n^{\text{Sp}})$, and given such a ν , N_{ν} is the set of partitions θ such that $\theta + \rho_{n-1}^{\text{Sp}}$ is a third row in at least one $T \in \text{SGT}^{\text{Sp}}(\lambda + \rho_n^{\text{Sp}})$ having $\nu + \rho_n$ as a second row. With these definitions, we can decompose L in (28) by summing over the possible choices for the second and third rows and “pull out” their contributions to L :

$$\begin{aligned} L(\lambda; t; z_1, \dots, z_n) &= \sum_{T \in \text{SGT}^{\text{Sp}}(\lambda + \rho_n^{\text{Sp}})} t^{r_e(T) + l_o(T)} (1+t)^{g(T)} \prod_{i=1}^n z_i^{d_i(T)} \\ &= \sum_{\nu \in M} \sum_{\theta \in N_{\nu}} t^{r(\lambda, \nu) + l(\nu, \theta)} (1+t)^{g(\lambda, \nu) + g(\nu, \theta)} z_1^{d_1(T)} L(\theta; t; z_2, \dots, z_n). \end{aligned} \tag{29}$$

Here we are using the notation $r(\lambda, \nu)$ to denote the number of right leaning terms (including 0) in $\nu + \rho_n$ given that $\lambda + \rho_n^{\text{Sp}}$ is above it. We analogously define $l(\nu, \theta)$ and $g(\lambda, \nu)$.

Now if we apply the inductive hypothesis to (29), then we have

$$\sum_{\nu \in M} \sum_{\theta \in N_{\nu}} t^{r(\lambda, \nu) + l(\nu, \theta)} (1+t)^{g(\lambda, \nu) + g(\nu, \theta)} z_1^{d_1(T)} R(\theta; t; z_2, \dots, z_n). \tag{30}$$

Define now C , which is constant with respect to ν and θ :

$$C = z^{-\rho_{n-1}^{\text{Sp}}} \prod_{i=2}^n (1 + tz_i^2) \prod_{1 < i < j \leq n} (1 + tz_i z_j) (1 + tz_i z_j^{-1}). \tag{31}$$

Hence, when we substitute the definition of R from (28) into (30), we get

$$C \sum_{\nu \in M} \sum_{\theta \in N_{\nu}} t^{r(\lambda, \nu) + l(\nu, \theta)} (1+t)^{g(\lambda, \nu) + g(\nu, \theta)} z_1^{d_1(T)} \chi_{\theta}^{\text{Sp}}(z_2, \dots, z_n). \tag{32}$$

Recall now that the symplectic character $\chi_{\theta}^{\text{Sp}}$ is given by Weyl’s character formula as

$$\chi_{\theta}^{\text{Sp}}(z) = \frac{\sum_{w \in W_{n-1}} (-1)^{\ell(w)} z^{w(\theta + \rho_{n-1}^{\text{Sp}})}}{\prod_{\alpha \in \Phi^+} (z^{\alpha/2} - z^{-\alpha/2})} = \frac{\sum_{w \in W_{n-1}} (-1)^{\ell(w)} z^{w(\theta + \rho_{n-1}^{\text{Sp}})}}{z^{-\rho_{n-1}^{\text{Sp}}} \prod_{i=2}^n (1 - z_i^2) \prod_{1 < i < j} (1 - z_i z_j) (1 - z_i z_j^{-1})} \tag{33}$$

where Φ^+ is the positive root system for $\mathrm{Sp}(2n-2)$; W_{n-1} is the Weyl group for $\mathrm{Sp}(2n-2)$, which is $(\mathbb{Z}/2\mathbb{Z})^{n-1} \rtimes S_{n-1}$, where we view $\mathbb{Z}/2\mathbb{Z} = \{-1, 1\}$ multiplicatively; and $\ell(w)$ is the length function on W . Denote the denominator of (33) by

$$b_\theta = z^{-\rho_{n-1}^{\mathrm{Sp}}} \prod_{i=2}^n (1 - z_i^2) \prod_{1 < i < j} (1 - z_i z_j)(1 - z_i z_j^{-1}).$$

Hence, (32) may be written

$$\begin{aligned} & \frac{C}{b_\theta} \sum_{\nu \in M} \sum_{\theta \in N_\nu} t^{r(\lambda, \nu) + l(\nu, \theta)} (1+t)^{g(\lambda, \nu) + g(\nu, \theta)} z_1^{d_1(T)} \sum_{w \in W_{n-1}} (-1)^{\ell(w)} z^{w(\theta + \rho_{n-1}^{\mathrm{Sp}})} \\ &= \frac{C}{b_\theta} \sum_{w \in W_{n-1}} (-1)^{\ell(w)} \sum_{\nu \in M} \sum_{\theta \in N_\nu} t^{r(\lambda, \nu) + l(\nu, \theta)} (1+t)^{g(\lambda, \nu) + g(\nu, \theta)} z_1^{d_1(T)} z^{w(\theta + \rho_{n-1}^{\mathrm{Sp}})}. \end{aligned} \quad (34)$$

Notice now that the terms in the sum depend entirely on the first three rows; there is no information used outside of this ‘‘partial’’ pattern. The expression (34) is entirely local.

As in the $\mathrm{GL}(n)$ case, we can expand the inner sum (the sum over $\theta \in N_\nu$) to include non-strict third rows without affecting the value of the sum. This is for the same reason as in the $\mathrm{GL}(n)$ case: we will get cancellation in the outer sum as we will have group elements that stabilize $\theta + \rho_{n-1}^{\mathrm{Sp}}$ but have opposite signs. Denote by N_ν^0 the set of $(n-1)$ -tuples θ such that $\theta + \rho_{n-1}^{\mathrm{Sp}}$ interleaves $\nu + \rho_n$. Then (34) becomes

$$\begin{aligned} & \frac{C}{b_\theta} \sum_{w \in W_{n-1}} (-1)^{\ell(w)} \sum_{\nu \in M} \sum_{\theta \in N_\nu} t^{r(\lambda, \nu) + l(\nu, \theta)} (1+t)^{g(\lambda, \nu) + g(\nu, \theta)} z_1^{d_1(T)} z^{w(\theta + \rho_{n-1}^{\mathrm{Sp}})} \\ &= \frac{C}{b_\theta} \sum_{w \in W_{n-1}} (-1)^{\ell(w)} \sum_{\nu \in M} \sum_{\theta \in N_\nu^0} t^{r(\lambda, \nu) + l(\nu, \theta)} (1+t)^{g(\lambda, \nu) + g(\nu, \theta)} z_1^{d_1(T)} z^{w(\theta + \rho_{n-1}^{\mathrm{Sp}})}. \end{aligned} \quad (35)$$

Note that we cannot expand the domain of ν , since W does not act on anything to do with the second row in the terms, and thus no cancellation can occur.

Similarly to the $\mathrm{GL}(n)$ case, we will use the term **partial $\mathrm{GT}^{\mathrm{Sp}}$ pattern** to mean a truncated $\mathrm{GT}^{\mathrm{Sp}}$ pattern having only three rows. In this context, we use the term to refer specifically to those partial $\mathrm{GT}^{\mathrm{Sp}}$ patterns whose first row is $\lambda + \rho_n^{\mathrm{Sp}}$. For a given $w \in W_{n-1}$ and partial $\mathrm{GT}^{\mathrm{Sp}}$ pattern T having second row $\nu + \rho_n$ and third row $\theta + \rho_{n-1}^{\mathrm{Sp}}$, we shall call the term of the form

$$(-1)^{\ell(w)} t^{r(\lambda, \nu) + l(\nu, \theta)} (1+t)^{g(\lambda, \nu) + g(\nu, \theta)} z_1^{d_1(T)} z^{w(\theta + \rho_{n-1}^{\mathrm{Sp}})}$$

the **partial weight of T with respect to w** . Unless we wish to bring attention to a particular $w \in W_{n-1}$, we shall omit mention of w and use ‘‘partial weight’’ for short.

As in the general linear case, our task is now to pair the partial symplectic GT patterns such that we may factor out each factor $(1 + tz_1^2)$, $(1 + tz_1 z_j)$, and $(1 + tz_1 z_j^{-1})$ from the sum of their partial weights. However, since we have three different factors, we will have three different pairings.

Our progress to this end is that we were able to construct an algorithm to make the $(1 + tz_1^2)$ pairings which has strong computational evidence, though we do not have a formal proof of its correctness. Moreover, for half of the $w \in W_{n-1}$, the $\mathrm{GT}^{\mathrm{Sp}}$ patterns may be paired in a manner almost identical to that of the general linear case to extract factors of $(1 + tz_1 z_j)$ and $(1 + tz_1 z_j^{-1})$, but the correct pairing for the other half of the $w \in W_{n-1}$ eludes our discovery. We begin with our conjectured algorithm for the $(1 + tz_1^2)$ pairing.

Algorithm 4.1 (Partial $\mathrm{GT}^{\mathrm{Sp}}$ Pattern Pairing Algorithm, $(1 + tz_1^2)$). *Fix $w \in W_{n-1}$. For each $\theta \in \bigcup_{\nu \in M} N_\nu^0$, let L_θ be the set of partial $\mathrm{GT}^{\mathrm{Sp}}$ patterns having third row $\theta + \rho_{n-1}^{\mathrm{Sp}}$, arranged in ascending lexicographic order with respect to the second row (this will also be the order in which we iterate over L_θ). For a given partial $\mathrm{GT}^{\mathrm{Sp}}$ pattern T having third row θ and second row ν , let also L'_θ be the set of partial $\mathrm{GT}^{\mathrm{Sp}}$ patterns that can be obtained by incrementing a single entry in ν by 1. Then the pairing proceeds as follows:*

```

let pairings = {}
for partition  $\theta \in \bigcup_{\nu \in M} N_\nu^0$ :
  for partial pattern  $T$  in  $L_\theta$ :
    let  $T.num\_unpaired = 2^{g(T)}$ 
  for partial pattern  $T_1$  in  $L_\theta$ :
    for partial pattern  $T_2$  in  $L_\theta$ :
      if  $T_2$  in  $L_\theta^\nu$ :
        let  $num\_connections = \min(T_1.num\_unpaired, T_2.num\_unpaired)$ 
        add  $(T_1, T_2)$  to pairings  $num\_connections$  times
         $T_1.num\_unpaired = T_1.num\_unpaired - num\_connections$ 
         $T_2.num\_unpaired = T_2.num\_unpaired - num\_connections$ 
return pairings

```

The idea behind algorithm 4.1 is that each pair (T_1, T_2) in *pairings* represents a pair of monomials (m_1, m_2) that appear in the partial weights of T_1 and T_2 , respectively, such that $tz_1^2 m_1 = m_2$, so that $m_1 + m_2 = (1 + tz_1^2)m_1$ (note that (T_1, T_2) may appear multiple times in *pairings*, each time corresponding to a distinct monomial pair). A valid monomial pair must exist between T_1 and T_2 since the second row of T_2 is obtained by incrementing a single entry in the second row of T_1 . Thus, the exponent on z_1 in the partial weight of T_2 is two less than that in T_1 , and there is some monomial m_2 whose exponent on t is one less than a monomial in m_1 (this is easy to see by cases). Note that the pairing algorithm is independent of $w \in W_{n-1}$, since the effect of w on the partial weight of a partial GT^{Sp} pattern is only to permute the order and flip the signs of the exponents on z_2, \dots, z_n , as well as to possibly flip the sign of the partial weight. Neither of these have bearing on the exponents of t and z_1 .

The reason that algorithm 4.1 is not proved correct is that for a given monomial m_1 in the partial weight of a partial GT^{Sp} pattern T_1 , there may be multiple other partial GT^{Sp} patterns whose partial weights contain a monomial m_2 that may be correctly matched with m_1 in the manner described previously. Thus, what needs to be checked is that the pairings of partial GT^{Sp} patterns constructed by algorithm 4.1 correctly pair the monomials, that is, each monomial in the partial weights of each partial GT^{Sp} pattern is paired exactly once. Computational evidence suggests the algorithm's correctness, including a successful pairing of the 1511664 partial GT^{Sp} patterns with top row $\lambda + \rho_n^{Sp} = (15, 13, 11, 9, 8, 7, 3, 2, 1)$. We thus have the conjecture:

Conjecture 4.1.1 (Partial GT^{Sp} Pattern Pairing Algorithm, $(1 + tz_1^2)$). *Algorithm 4.1 gives, independent of $w \in W_{n-1}$, a pairing of partial symplectic GT patterns such that each pair (T_1, T_2) corresponds to exactly one pair of monomials (m_1, m_2) appearing in the partial weights of (T_1, T_2) satisfying $m_1 + m_2 = (1 + tz_1^2)m_1$. Moreover, each monomial from each partial GT^{Sp} pattern corresponds to exactly one pairing of partial GT^{Sp} patterns, so that $(1 + tz_1^2)$ divides (35).*

We now present the progress we have made toward factoring out the binomials $(1 + tz_1 z_j)$ and $(1 + tz_1 z_j^{-1})$. The observation we make is that the second and third rows of a partial GT^{Sp} pattern together form a partial GT pattern, as shown in figure 18.

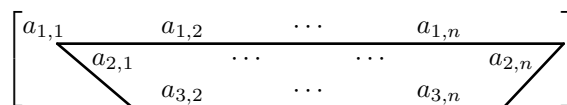

Figure 18: The second and third rows of a partial GT^{Sp} pattern together form a partial GT pattern, outlined above in the trapezoid.

Suppose now that the Weyl group element $w \in W_{n-1}$ is the identity, $w = 1$. If we fix a second row $\nu + \rho_n$ for some $\nu \in M$ and pair the partial GT^{Sp} patterns with that second row in a manner identical to that of the $GL(n)$ case by considering the second and third rows to be partial GT patterns, then we find that the sum of the partial weights is divisible by $(1 + tz_1 z_j)$. The reason is that if T_1 is a partial GT^{Sp} pattern having second row $\nu + \rho_n$, and we obtain T_2 by increment the $(j - 1)$ -st entry of the third row of T_1 by 1,

The next few results encompass our partial progress towards proving the Combinatorial symplectic Tokuyama formula.

Proposition 4.1.2. *The factor $1 + tz_1^2$ divides*

$$\sum_{T \in \text{PSGT}(\lambda + \rho_n^{\text{Sp}})} t^{\# \text{ primed}} \prod_{i=1}^n z_i^{d_i(T)}$$

Proof. Notice that increasing an entry by one and removing a prime on the second row of a primed strict symplectic GT pattern is the same as multiplying the weight of the pattern by $1/tz_1^2$. Similarly, decreasing an entry by one and putting a prime is the same as multiplying the weight of the pattern by tz_1^2 . Because the third row has one element less than the second row, the configuration is exactly the same as in Proposition 3.0.2. Thus, the proposition follows from Proposition 3.0.2. \square

Remark 4.3. *Proposition 4.1.2 immediately implies divisibility of the sum by all factors $1 + tz_i^2$.*

4.4.1 The Factor $1 + tz_1z_2$

The combinatorial method still has not managed to prove divisibility of the sum over primed strict symplectic GT patterns by the factor $1 + tz_1z_2$. Nevertheless, we have made partial progress.

Definition 4.6 (Pairing algorithm that pairs almost all patterns). *Take the first entry from left to right for which we can either*

- *increase the entry by one and put a prime, or*
- *decrease the entry by one and remove a prime*

Notice that increasing the third row by one and putting a prime is the same as multiplying the weight by tz_1z_2 . Similarly, decreasing the third row by one and removing a prime is the same as multiplying the weight by $1/tz_1z_2$.

Example 4.3.1.

$$\begin{array}{cccc} 3 & 2 & 1 & \\ & 3 & 2 & 1 \\ & & 2 & 1 \\ & & & 2' \\ & & & & 0' \\ & & & & & t^2 z_1^{-3} z_2^{-1} \end{array} \leftrightarrow \begin{array}{cccc} 3 & 2 & 1 & \\ & 3 & 2 & 1 \\ & & 3' & 1 \\ & & & 2 & 1 \\ & & & & 2' \\ & & & & & 0' \\ & & & & & t^3 z_1^{-2} \end{array}$$

Unfortunately, we cannot use the pairing algorithm 4.6 to pair up all primed strict symplectic GT patterns. The reason is the fourth row. For $\text{GL}(n)$ each consecutive row has one element less. Here the fourth row has the same number of entries as the third row, so it can prevent the pairing algorithm from $\text{GL}(n)$ to be executed. Nevertheless, for the subset of patterns for which the algorithm is well-defined, it is an involution.

Lemma 4.1.1 (Involution). *The pairing algorithm from Definition 4.6 is an involution.*

Proof. The proof is the same as in Lemma 3.0.3. \square

An idea that helps a lot is to first pair all GT patterns for which the pairing algorithm above works. Then we will only be left with patterns for which the pairing algorithm cannot be executed and which have a very restrictive structure.

Recall the frozen configurations of c' which we defined for $\text{GL}(n)$ (Definition 3.4).

$$\begin{array}{ccc} \text{2nd row} & c' & c' \\ \text{3rd row} & c' & c - 1 \end{array}$$

Because on even rows of symplectic GT patterns we prime right-leaning entries, we have to modify the frozen states of c' on the third row of symplectic patterns accordingly.

Definition 4.7 (Frozen States). *The frozen states of c' on the third row of a primed strict symplectic GT pattern are defined to be the following configurations:*

$$\begin{array}{ccc} \text{3rd row} & c' & c' \\ \text{4th row} & c & c - 1' \end{array}$$

We now show that if we cannot pair a primed strict symplectic GT pattern with the algorithm 4.6 then the pattern must have a very specific structure.

Lemma 4.1.2 (Divide-and-conquer). *Suppose that a symplectic GT pattern cannot be paired by using 4.6. Then all of the entries on the third row are in a frozen state and are primed.*

Proof. The first part of the proposition follows directly from Lemma 3.0.1. To prove all entries on the third row are primed notice that an entry on the 4th row cannot freeze more than one entry on the third row. This implies each entry on the the third row forms a frozen state with the entry below it on the right. But by Definition 4.7 the only such frozen states have a primed entry on the third row. This concludes the proof. \square

Example 4.3.2. $\lambda = (0, 0)$. Then $\rho_2^{\text{Sp}} = (2, 1)$. There are 16 patterns. 8 of them can be paired using the algorithm in definition 4.6:

$$\begin{array}{ccc} \begin{array}{ccc} 2 & 1 & \\ & 2 & 1 \\ & 2' & \\ & & 1 \end{array} & \leftrightarrow & \begin{array}{ccc} 2 & 1 & \\ & 2 & 1 \\ & & 1 \\ & & 1 \end{array} \\ \begin{array}{ccc} 2 & 1 & \\ & 2 & 1 \\ & 2' & \\ & & 0' \end{array} & \leftrightarrow & \begin{array}{ccc} 2 & 1 & \\ & 2 & 1 \\ & & 1 \\ & & 0' \end{array} \\ \begin{array}{ccc} 2 & 1 & \\ & 2 & 0' \\ & 2' & \\ & & 1 \end{array} & \leftrightarrow & \begin{array}{ccc} 2 & 1 & \\ & 2 & 0' \\ & & 1 \\ & & 1 \end{array} \\ \begin{array}{ccc} 2 & 1 & \\ & 2 & 0' \\ & 2' & \\ & & 0'' \end{array} & \leftrightarrow & \begin{array}{ccc} 2 & 1 & \\ & 2 & 0' \\ & & 1 \\ & & 0' \end{array} \end{array}$$

The other 8 patterns cannot be paired with 4.6. All entries on their third row are in a frozen state. Observe that Lemma 4.1.2 hold for these 8 remaining patterns. We pair them up as well.

$$\begin{array}{ccc} \begin{array}{ccc} 2 & 1 & \\ & 2 & 1 \\ & 2' & \\ & & 2 \end{array} & \xleftrightarrow{\text{Type 1}} & \begin{array}{ccc} 2 & 1 & \\ & 2 & 0' \\ & & 1' \\ & & 1 \end{array} \\ \begin{array}{ccc} 2 & 1 & \\ & 2 & 1 \\ & 2' & \\ & & 1' \end{array} & \xleftrightarrow{\text{Type 1}} & \begin{array}{ccc} 2 & 1 & \\ & 2 & 0' \\ & & 1' \\ & & 0' \end{array} \\ \begin{array}{ccc} 2 & 1 & \\ & 2 & 0' \\ & 2' & \\ & & 2 \end{array} & \xleftrightarrow{\text{Type 1}} & \begin{array}{ccc} 2 & 1 & \\ & 1' & 0' \\ & & 1' \\ & & 1 \end{array} \\ \begin{array}{ccc} 2 & 1 & \\ & 2 & 0' \\ & 2' & \\ & & 1' \end{array} & \xleftrightarrow{\text{Type 1}} & \begin{array}{ccc} 2 & 1 & \\ & 1' & 0' \\ & & 1' \\ & & 0' \end{array} \end{array}$$

4.4.2 Remarks on the Combinatorial Method

Here we describe a semi-formal algorithm which we hope to use in the future to complete the pairing for the factor $1 + tz_1z_2$.

Definition 4.8 (Non-Rigorous Algorithm).

- increase/decrease and remove/put a prime on the second row. Note this is different from Definition 4.6 because on even rows we prime right-leaning entries.
- increase/decrease the third row without changing the number of primes and increase/decrease the fourth row without changing the number of primes. Note that the operations in the second bullet should not change the fact that all entries in the third row are in a frozen state. This implies the transformations in the second bullet are quite restricted. There are two types:

Type 1: We change one frozen state

$$\begin{array}{ccc} \text{3rd row} & c' & \\ \text{4th row} & c & \end{array} \leftrightarrow \begin{array}{ccc} c-1' & & \\ & c-1 & \end{array} \quad \text{or}$$

$$\begin{array}{ccc} \text{3rd row} & c' & \\ \text{4th row} & c-1' & \end{array} \leftrightarrow \begin{array}{ccc} c-1' & & \\ & c-2' & \end{array}$$

Type 2: We change two frozen states.

$$\begin{array}{ccccccc} \text{3rd row} & c' & \dots & & d' & & \\ \text{4th row} & c & & & & & d-1' \end{array} \leftrightarrow \begin{array}{ccccccc} c' & & \dots & & & & d-1' \\ & c-1' & & & \dots & & d-1 \end{array} \quad \text{or}$$

$$\begin{array}{ccccccc} \text{3rd row} & d' & & & \dots & & c' \\ \text{4th row} & & d-1' & & \dots & & c \end{array} \leftrightarrow \begin{array}{ccccccc} d-1' & & \dots & & & & c' \\ & d-1 & & & \dots & & c-1' \end{array}$$

Notice there was a prime switch on the fourth row, but nevertheless the total number of primes remained the same.

For $\lambda = (0, 0, 0)$ we need both Type 1 and Type 2 transformations to pair all patterns.

Example 4.3.3. Let $\lambda = (0, 0, 0)$ and so $\rho_3^{\text{Sp}} = (3, 2, 1)$. First pair everything possible with the algorithm 4.8. We do not list these. For the sake of brevity, we write $[a_1, \dots, a_m]$ when we can use either of the entries a_1, \dots, a_m and that does not change the pairings. We will not write the sixth row as that does not influence the pairings. Here are the pairings which use the algorithm 4.8 and that cannot be paired with Definition 4.6.

$$\begin{array}{cccc} 3 & 2 & 1 & \\ & 3 & 2 & 1 \\ & & 3' & 2' \\ & & & 3 & 2 \\ & & & & [3', 2] \end{array} \xleftrightarrow{\text{Type 1}} \begin{array}{cccc} 3 & 2 & 1 & \\ & 3 & 2 & 0' \\ & & 3' & 1' \\ & & & 3 & 1 \\ & & & & [3', 2] \end{array}$$

$$\begin{array}{cccc} 3 & 2 & 1 & \\ & 3 & 2 & 1 \\ & & 3' & 2' \\ & & & 3 & 1' \\ & & & & [3', 2', 2, 1] \end{array} \xleftrightarrow{\text{Type 1}} \begin{array}{cccc} 3 & 2 & 1 & \\ & 3 & 2 & 0' \\ & & 3' & 1' \\ & & & 3 & 0' \\ & & & & [3', 2', 2, 1] \end{array}$$

$$\begin{array}{cccc} 3 & 2 & 1 & \\ & 3 & 2 & 1 \\ & & 3' & 2' \\ & & & 2' & 1' \\ & & & & [2', 1] \end{array} \xleftrightarrow{\text{Type 1}} \begin{array}{cccc} 3 & 2 & 1 & \\ & 3 & 2 & 0' \\ & & 3' & 1' \\ & & & 2 & 0' \\ & & & & [2', 1] \end{array}$$

$$\begin{array}{cccc}
3 & 2 & 1 & \\
& 3 & 1' & 0' \\
& & 3' & 1' \\
& & & 2' \\
& & & & 0' \\
& & & & & [1', 0]
\end{array}
\begin{array}{c}
\leftarrow \text{Type 1} \rightarrow
\end{array}
\begin{array}{cccc}
3 & 2 & 1 & \\
& 2' & 1' & 0' \\
& & 2' & 1' \\
& & & 1' \\
& & & & 0' \\
& & & & & [1', 0]
\end{array}$$

Now the question becomes how can we make Algorithm 4.8 completely rigorous. For now it seems that there will be a big amount of casework.

Here is one more complicated example which demonstrates the Type 2 transformation in the algorithm 4.8:

Example 4.3.4.

$$\begin{array}{cccccc}
5 & 4 & 3 & 2 & 1 & \\
& 5 & 4 & 3 & 1' & 0' \\
& & 5' & 4' & 3' & 1' \\
& & & 5 & 3' & 2' \\
& & & & 4' & 2 \\
& & & & & 1
\end{array}
\begin{array}{c}
\leftarrow \text{Type 2} \rightarrow
\end{array}
\begin{array}{cccccc}
5 & 4 & 3 & 2 & 1 & \\
& 5 & 4 & 2' & 1' & 0' \\
& & 5' & 4' & 2' & 1' \\
& & & 4' & 3' & 2 \\
& & & & 4' & 2 \\
& & & & & 1
\end{array}$$

Again note the prime switch on the fourth row. The rows 6 – 10 are not included as they do not influence the pairing.

5 Conclusion

5.1 Future Directions

We have many future directions we would like to take our research. First and foremost, we seek to complete our two proofs for the Symplectic Group by formally proving the pairing algorithm for the direct case and using the “divide-and-conquer” technique in the combinatorial case. Secondly, we are also interested in related our work back to solvable lattice models, which form a promising language related to Tokuyama’s formula. Specifically, we want to find a solvable lattice model for primed Gelfand-Tsetlin patterns. Since the weights associated with these primed patterns are simpler, finding solvable lattice models associated with them would be helpful for manipulation in other proofs. Finally, our long-term goals include finding and proving a Tokuyama’s formula for orthogonal groups (Type B) and indeed all reductive groups, perhaps using the language of crystal bases, which treat all such Lie groups uniformly.

5.2 Acknowledgments

The authors would like to acknowledge Slava Naprienko, our graduate student mentor who led our exploration of this topic and gave feedback on our draft. We would also like to acknowledge SURIM, the program which brought us together, and especially Pawel Grzegorzolka, the director of this program, who selected the groups and also gave feedback on our draft. Finally, we would like to acknowledge Stanford University, for supporting us with a stipend during our work and making SURIM itself possible.

References

[BBF10] Ben Brubaker, Daniel Bump, and Solomon Friedberg. *Schur Polynomials and the Yang-Baxter equation*. 2010. arXiv: 0912.0911 [math.CO].

[FZ16] Solomon Friedberg and Lei Zhang. “Tokuyama-type formulas for characters of type B”. In: *Israel Journal of Mathematics* 216 (2016), pp. 617–655. DOI: <https://doi.org/10.1007/s11856-016-1422-6>. URL: <https://link.springer.com/article/10.1007/s11856-016-1422-6>.

[Iva12] Dmitriy Ivanov. “Symplectic Ice”. In: *Multiple Dirichlet Series, L-functions and Automorphic Forms*. Ed. by Daniel Bump, Solomon Friedberg, and Dorian Goldfeld. 2012. Chap. 10. DOI: https://doi.org/10.1007/978-0-8176-8334-4_10.

- [Mac95] I. G. Macdonald. *Symmetric Functions and Hall Polynomials*. Oxford University Press, Inc., 1995. ISBN: 9780198739128.
- [Nap21] Slava Naprienko. *Simple Proof of Tokuyama’s Formula*. 2021. URL: <https://thuses.com/combinatorics/simple-proof-of-tokuyamas-formula/>.
- [Oka90] Soichi Okada. “Partially strict shifted plane partitions”. In: *Journal of Combinatorial Theory, Series A* 53.1 (1990), pp. 143–156. ISSN: 0097-3165. DOI: [https://doi.org/10.1016/0097-3165\(90\)90025-R](https://doi.org/10.1016/0097-3165(90)90025-R). URL: <https://www.sciencedirect.com/science/article/pii/009731659090025R>.
- [Pro94] R.A. Proctor. “Young Tableaux, Gelfand Patterns, and Branching Rules for Classical Groups”. In: *Journal of Algebra* 164.2 (1994), pp. 299–360. ISSN: 0021-8693. DOI: <https://doi.org/10.1006/jabr.1994.1064>. URL: <https://www.sciencedirect.com/science/article/pii/S0021869384710647>.
- [Wac85] Michelle L. Wachs. “Flagged Schur functions, Schubert polynomials, and symmetrizing operators”. In: *Journal of Combinatorial Theory* 40 (1985), pp. 276–289. DOI: [https://doi.org/10.1016/0097-3165\(85\)90091-3](https://doi.org/10.1016/0097-3165(85)90091-3). URL: <https://www.sciencedirect.com/science/article/pii/0097316585900913>.